

LMK61PD0A2 Ultra-Low Jitter Pin Selectable Oscillator

1 Features

- Ultra-low Noise, High Performance
 - Jitter: 90 fs RMS typical $f_{OUT} > 100$ MHz
 - PSRR: -70 dBc, robust supply noise immunity
- Flexible Output Frequency and Format; User Selectable
 - Frequencies: 62.5 MHz, 100 MHz, 106.25 MHz, 125 MHz, 156.25 MHz, 212.5 MHz, 312.5 MHz
 - Formats: LVPECL, LVDS or HCSL
- Total frequency tolerance of ± 50 ppm
- Internal memory stores multiple start-up configurations, selectable through pin control
- 3.3V operating voltage
- Industrial temperature range (-40°C to +85°C)
- 7 mm x 5 mm 8-pin package

2 Applications

- High-performance replacement for crystal-, SAW-, or silicon-based Oscillators
- Switches, Routers, Network Line Cards, Base Band Units (BBU), Servers, Storage/SAN
- Test and Measurement
- Medical Imaging
- FPGA, Processor Attach

3 Description

The LMK61PD0A2 is an ultra-low jitter PLLatinum™ pin selectable oscillator that generates commonly used reference clocks. The device is pre-programmed in factory to support seven unique reference clock frequencies that can be selected by pin-strapping each of FS[1:0] to VDD, GND or NC (no connect). Output format is selected between LVPECL, LVDS, or HCSL by pin-strapping OS to VDD, GND or NC. Internal power conditioning provide excellent power supply ripple rejection (PSRR), reducing the cost and complexity of the power delivery network. The device operates from a single 3.3 V $\pm 5\%$ supply.

Device Information⁽¹⁾

PART NUMBER	PACKAGE	BODY SIZE (NOM)
LMK61PD0A2	8-pin QFM (SIA)	7.0 mm x 5.0 mm

(1) For all available packages, see the orderable addendum at the end of the data sheet.

Pinout and Simplified Block Diagram

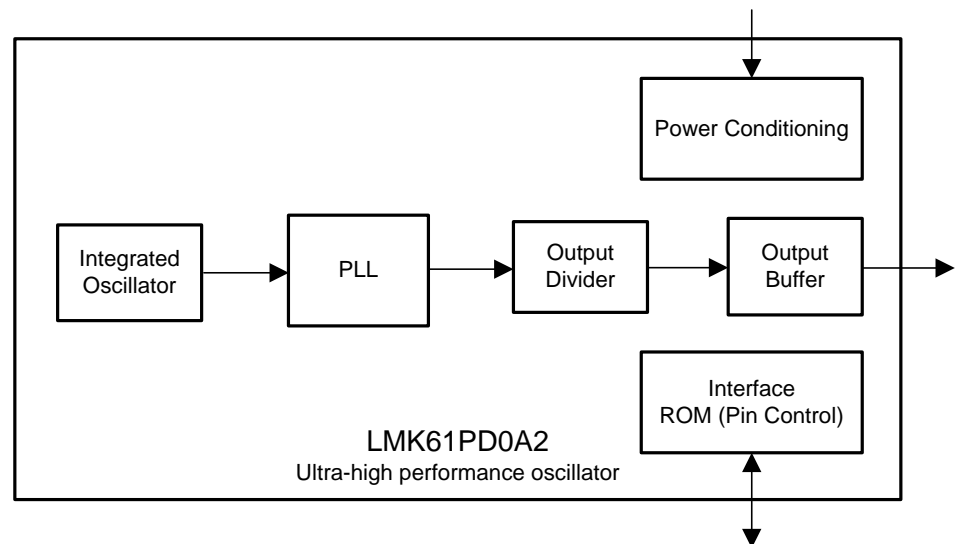
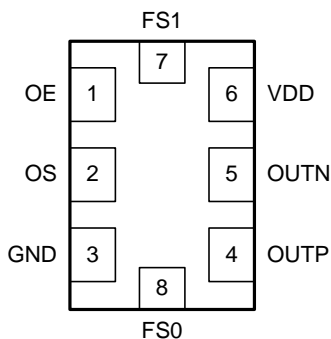

Table of Contents

1 Features	1	7.15 Additional Reliability and Qualification	9
2 Applications	1	7.16 Typical Performance Characteristics	10
3 Description	1	8 Parameter Measurement Information	11
4 Revision History	2	8.1 Device Output Configurations	11
5 Device Control	3	9 Detailed Description	13
6 Pin Configuration and Functions	4	9.1 Overview	13
7 Specifications	5	9.2 Functional Block Diagram	13
7.1 Absolute Maximum Ratings	5	9.3 Feature Description	13
7.2 ESD Ratings	5	10 Application and Implementation	14
7.3 Recommended Operating Conditions	5	10.1 Application Information	14
7.4 Thermal Information	5	10.2 Typical Application	14
7.5 Electrical Characteristics - Power Supply	6	11 Power Supply Recommendations	16
7.6 LVPECL Output Characteristics	6	12 Layout	17
7.7 LVDS Output Characteristics	6	12.1 Layout Guidelines	17
7.8 HCSL Output Characteristics	7	13 Device and Documentation Support	19
7.9 OE Input Characteristics	7	13.1 Community Resources	19
7.10 OS, FS[1:0] Input Characteristics	7	13.2 Trademarks	19
7.11 Frequency Tolerance Characteristics	7	13.3 Electrostatic Discharge Caution	19
7.12 Power-On/Reset Characteristics (VDD)	8	13.4 Glossary	19
7.13 PSRR Characteristics	8	14 Mechanical, Packaging, and Orderable Information	19
7.14 PLL Clock Output Jitter Characteristics	9		

4 Revision History

Changes from Original (October 2015) to Revision A

Page

• Product Preview to Production Data Release	1
--	----------

5 Device Control

Table 1. Output Frequency Mapping for FS[1:0] Selection

FS1	FS0	OUT FREQUENCY (MHz)	RELEVANT STANDARDS
0	0	100	PCI Express
0	NC	312.5	10 Gbps Ethernet
0	1	125	1 Gbps Ethernet
NC	0	106.25	Fiber Channel
NC	NC	156.25	10 Gbps Ethernet
NC	1	212.5	Fiber Channel
1	0	62.5	1 Gbps Ethernet
1	NC	Reserved	n/a
1	1	Reserved	n/a

Table 2. Output Type Mapping for OS, OE Selection

OS	OE	OUTPUT TYPE
X	0	Disabled (PLL functional)
0	1	LVPECL
NC	1	LVDS
1	1	HCSL

6 Pin Configuration and Functions

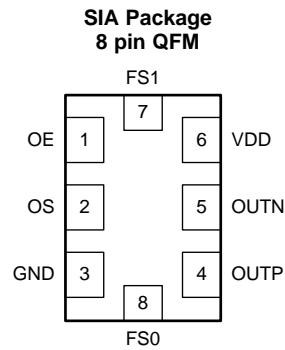
Table 3. Pin Functions

PIN		I/O	DESCRIPTION
NAME	NO.		
POWER			
GND	3	Ground	Device Ground.
VDD	6	Analog	3.3 V Power Supply.
OUTPUT BLOCK			
OUTP, OUTN	4, 5	Universal	Differential Output Pair (LVPECL, LVDS or HCSL).
DIGITAL CONTROL / INTERFACES			
FS[1:0]	7, 8	LVC MOS	Output Frequency Select. Refer to Table 1 .
OE	1	LVC MOS	Output Enable (internal pullup). Refer to Table 2 .
OS	3	LVC MOS	Output Type Select. Refer to Table 2 .

7 Specifications

7.1 Absolute Maximum Ratings

over operating free-air temperature range (unless otherwise noted)⁽¹⁾

		MIN	MAX	UNIT
VDD	Device Supply Voltage	-0.3	3.6	V
V _{IN}	Output Voltage Range for Logic Inputs	-0.3	VDD + 0.3	V
V _{OUT}	Output Voltage Range for Clock Outputs	-0.3	VDD + 0.3	V
T _J	Junction Temperature		150	°C
T _{STG}	Storage Temperature	-40	125	°C

(1) Stresses beyond those listed under *Absolute Maximum Ratings* may cause permanent damage to the device. These are stress ratings only, which do not imply functional operation of the device at these or any other conditions beyond those indicated under *Recommended Operating Conditions*. Exposure to absolute maximum-rated conditions for extended periods may affect device reliability.

7.2 ESD Ratings

		VALUE	UNIT
V _(ESD)	Electrostatic discharge	Human-body model (HBM), per ANSI/ESDA/JEDEC JS-001 ⁽¹⁾	V
		Charged-device model (CDM), per JEDEC specification JESD22-C101 ⁽²⁾	
		±4000	
		±1500	

(1) JEDEC document JEP155 states that 500 V HBM allows safe manufacturing with a standard ESD control process.

(2) JEDEC document JEP157 states that 250 V CDM allows safe manufacturing with a standard ESD control process.

7.3 Recommended Operating Conditions

over operating free-air temperature range (unless otherwise noted)

		MIN	NOM	MAX	UNIT
VDD	Device Supply Voltage	3.135	3.3	3.465	V
T _A	Ambient Temperature	-40	25	85	°C
T _J	Junction Temperature			125	°C
t _{RAMP}	VDD Power-Up Ramp Time	0.1		100	ms

7.4 Thermal Information

THERMAL METRIC ⁽¹⁾	LMK61PD0A2 ⁽²⁾ ⁽³⁾ ⁽⁴⁾			UNIT	
	QFM (SIA)				
	8 PINS				
	Airflow (LFM) 0	Airflow (LFM) 200	Airflow (LFM) 400		
R _{θJA}	Junction-to-ambient thermal resistance	54	44	41.2	°C/W
R _{θJC(top)}	Junction-to-case (top) thermal resistance	34	n/a	n/a	
R _{θJB}	Junction-to-board thermal resistance	36.7	n/a	n/a	
ψ _{JT}	Junction-to-top characterization parameter	11.2	16.9	21.9	
ψ _{JB}	Junction-to-board characterization parameter	36.7	37.8	38.9	
R _{θJC(bot)}	Junction-to-case (bottom) thermal resistance	n/a	n/a	n/a	

(1) For more information about traditional and new thermal metrics, see the *Semiconductor and IC Package Thermal Metrics* application report, [SPRA953](#).

(2) The package thermal resistance is calculated on a 4 layer JEDEC board.

(3) Connected to GND with 3 thermal vias (0.3-mm diameter).

(4) ψ_{JB} (junction to board) is used when the main heat flow is from the junction to the GND pad. Please refer to Thermal Considerations section for more information on ensuring good system reliability and quality.

LMK61PD0A2

SNAS675A –OCTOBER 2015–REVISED NOVEMBER 2015

www.ti.com
7.5 Electrical Characteristics - Power Supply⁽¹⁾
 $V_{DD} = 3.3\text{ V} \pm 5\%$, $T_A = -40\text{C}$ to 85C

PARAMETER		TEST CONDITIONS	MIN	TYP	MAX	UNIT
IDD	Device Current Consumption	LVPECL ⁽²⁾		162	208	mA
		LVDS		152	196	
		HCSL		155	196	
IDD-PD	Device Current Consumption when output is disabled	OE = GND		136		

(1) Refer to Parameter Measurement Information for relevant test conditions.

(2) On-chip power dissipation should exclude 40 mW, dissipated in the 150 ohm termination resistors, from total power dissipation.

7.6 LVPECL Output Characteristics⁽¹⁾
 $V_{DD} = 3.3\text{ V} \pm 5\%$, $T_A = -40\text{C}$ to 85C

PARAMETER		TEST CONDITIONS	MIN	TYP	MAX	UNIT
f_{OUT}	Output Frequency ⁽²⁾		62.5		312.5	MHz
V_{OD}	Output Voltage Swing ($V_{OH} - V_{OL}$) ⁽²⁾		700	800	1200	mV
$V_{OUT, DIFF, PP}$	Differential Output Peak-to-Peak Swing			2 x $ V_{OD} $		V
V_{OS}	Output Common Mode Voltage			$V_{DD} - 1.55$		V
t_R / t_F	Output Rise/Fall Time (20% to 80%) ⁽³⁾			120	200	ps
PN-Floor	Output Phase Noise Floor ($f_{OFFSET} > 10\text{ MHz}$)	156.25 MHz		-165		dBc/Hz
ODC	Output Duty Cycle ⁽³⁾		45%		55%	

(1) Refer to Parameter Measurement Information for relevant test conditions.

(2) An output frequency over f_{OUT} max spec is possible, but output swing may be less than V_{OD} min spec.

(3) Ensured by characterization.

7.7 LVDS Output Characteristics⁽¹⁾
 $V_{DD} = 3.3\text{ V} \pm 5\%$, $T_A = -40\text{C}$ to 85C

PARAMETER		TEST CONDITIONS	MIN	TYP	MAX	UNIT
f_{OUT}	Output Frequency ⁽¹⁾		62.5		312.5	MHz
V_{OD}	Output Voltage Swing ($V_{OH} - V_{OL}$) ⁽¹⁾		300	390	480	mV
$V_{OUT, DIFF, PP}$	Differential Output Peak-to-Peak Swing			2 x $ V_{OD} $		V
V_{OS}	Output Common Mode Voltage			1.2		V
t_R / t_F	Output Rise/Fall Time (20% to 80%) ⁽²⁾			150	250	ps
PN-Floor	Output Phase Noise Floor ($f_{OFFSET} > 10\text{ MHz}$)	156.25 MHz		-162		dBc/Hz
ODC	Output Duty Cycle ⁽²⁾		45%		55%	
R_{OUT}	Differential Output Impedance			125		Ohm

(1) An output frequency over f_{OUT} max spec is possible, but output swing may be less than V_{OD} min spec.

(2) Ensured by characterization.

7.8 HCSL Output Characteristics⁽¹⁾

 $V_{DD} = 3.3\text{ V} \pm 5\%$, $T_A = -40^\circ\text{C}$ to 85°C

PARAMETER	TEST CONDITIONS	MIN	TYP	MAX	UNIT
f_{OUT}	Output Frequency	62.5		312.5	MHz
V_{OH}	Output High Voltage	600		850	mV
V_{OL}	Output Low Voltage	-100		100	mV
V_{CROSS}	Absolute Crossing Voltage ⁽²⁾⁽³⁾	250		475	mV
$V_{CROSS-DELTA}$	Variation of V_{CROSS} ⁽²⁾⁽³⁾	0		140	mV
dV/dt	Slew Rate ⁽⁴⁾	0.8		2	V/ns
PN-Floor	Output Phase Noise Floor ($f_{OFFSET} > 10\text{ MHz}$)	100 MHz		-164	dBc/Hz
ODC	Output Duty Cycle ⁽⁴⁾	45%		55%	

(1) Refer to Parameter Measurement Information for relevant test conditions.

(2) Measured from -150 mV to +150 mV on the differential waveform with the 300 mVpp measurement window centered on the differential zero crossing.

(3) Ensured by design.

(4) Ensured by characterization.

7.9 OE Input Characteristics

 $V_{DD} = 3.3\text{ V} \pm 5\%$, $T_A = -40^\circ\text{C}$ to 85°C

PARAMETER	TEST CONDITIONS	MIN	TYP	MAX	UNIT
V_{IH}	Input High Voltage	1.4			V
V_{IL}	Input Low Voltage			0.6	V
I_{IH}	Input High Current	$V_{IH} = V_{DD}$		40	uA
I_{IL}	Input Low Current	$V_{IL} = \text{GND}$		40	uA
C_{IN}	Input Capacitance		2		pF

7.10 OS, FS[1:0] Input Characteristics

 $V_{DD} = 3.3\text{ V} \pm 5\%$, $T_A = -40^\circ\text{C}$ to 85°C

PARAMETER	TEST CONDITIONS	MIN	TYP	MAX	UNIT
V_{IH}	Input High Voltage	1.4			V
V_{IL}	Input Low Voltage			0.4	V
I_{IH}	Input High Current	$V_{IH} = V_{DD}$		40	uA
I_{IL}	Input Low Current	$V_{IL} = \text{GND}$		40	uA
C_{IN}	Input Capacitance		2		pF

7.11 Frequency Tolerance Characteristics⁽¹⁾

 $V_{DD} = 3.3\text{ V} \pm 5\%$, $T_A = -40^\circ\text{C}$ to 85°C

PARAMETER	TEST CONDITIONS	MIN	TYP	MAX	UNIT	
f_T	Total Frequency Tolerance	All output formats, frequency bands and device junction temperature up to 125°C ; includes initial freq tolerance, temperature & supply voltage variation, solder reflow and aging (10 years)	-50		50	ppm

(1) Ensured by characterization.

LMK61PD0A2

SNAS675A –OCTOBER 2015–REVISED NOVEMBER 2015

www.ti.com
7.12 Power-On/Reset Characteristics (VDD)

 VDD = 3.3 V ± 5%, T_A = -40°C to 85°C

PARAMETER		TEST CONDITIONS	MIN	TYP	MAX	UNIT
V _{THRESH}	Threshold Voltage ⁽¹⁾		2.72		2.95	V
V _{DROOP}	Allowable Voltage Droop ⁽²⁾				0.1	V
t _{STARTUP}	Startup Time ⁽¹⁾	Time elapsed from VDD at 3.135 V to output enabled			10	ms
t _{OE-EN}	Output enable time ⁽²⁾	Time elapsed from OE at V _{IH} to output enabled			50	us
t _{OE-DIS}	Output disable time ⁽²⁾	Time elapsed from OE at V _{IL} to output disabled			50	us

(1) Ensured by characterization.

(2) Ensured by design.

7.13 PSRR Characteristics⁽¹⁾

 VDD = 3.3 V, T_A = 25°C, FS[1:0] = NC, NC

PARAMETER		TEST CONDITIONS	MIN	TYP	MAX	UNIT
PSRR	Spurs Induced by 50 mV Power Supply Ripple ⁽²⁾⁽³⁾ at 156.25 MHz output, all output types	Sine wave at 50 kHz		-70		dBc
		Sine wave at 100 kHz		-70		
		Sine wave at 500 kHz		-70		
		Sine wave at 1 MHz		-70		

(1) Refer to Parameter Measurement Information for relevant test conditions.

(2) Measured max spur level with 50 mVpp sinusoidal signal between 50 kHz and 1 MHz applied on VDD pin

 (3) $DJ_{SPUR} (ps, pk-pk) = [2 \cdot 10 \cdot (SPUR/20) / (\pi \cdot f_{OUT})] \cdot 1e6$, where PSRR or SPUR in dBc and f_{OUT} in MHz.

7.14 PLL Clock Output Jitter Characteristics⁽¹⁾⁽²⁾

VDD = 3.3 V ± 5%, T_A = -40°C to 85°C

PARAMETER		TEST CONDITIONS	MIN	TYP	MAX	UNIT
RJ	RMS Phase Jitter ⁽³⁾ (12 kHz – 20 MHz) (1 kHz – 5 MHz)	f _{OUT} ≥ 100 MHz, All output frequencies and output types		100	200	fs RMS
RJ	RMS Phase Jitter ⁽³⁾ (12 kHz – 20 MHz) (1 kHz – 5 MHz)	f _{OUT} = 62.5 MHz, All output frequencies and output types		200	400	fs RMS

- (1) Refer to Parameter Measurement Information for relevant test conditions.
 (2) Phase jitter measured with Agilent E5052 signal source analyzer using a differential-to-single ended converter (balun or buffer).
 (3) Ensured by characterization.

7.15 Additional Reliability and Qualification

PARAMETER	CONDITION / TEST METHOD
Mechanical Shock	MIL-STD-202, Method 213
Mechanical Vibration	MIL-STD-202, Method 204
Moisture Sensitivity Level	J-STD-020, MSL3

7.16 Typical Performance Characteristics

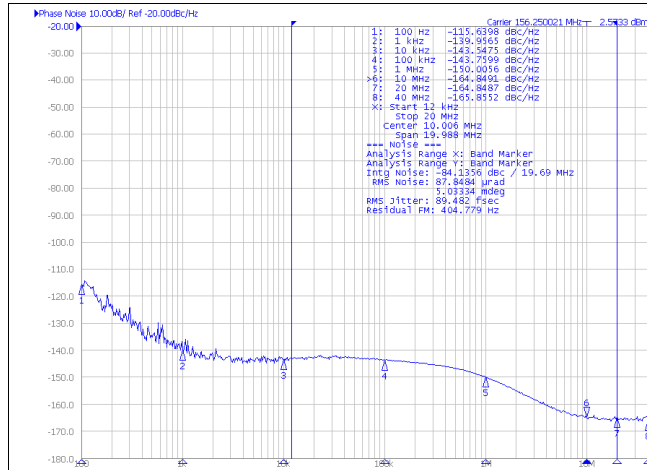

Figure 1. Phase Noise of LVPECL Differential Output at 156.25 MHz with FS[1:0] = NC, NC, OS = GND

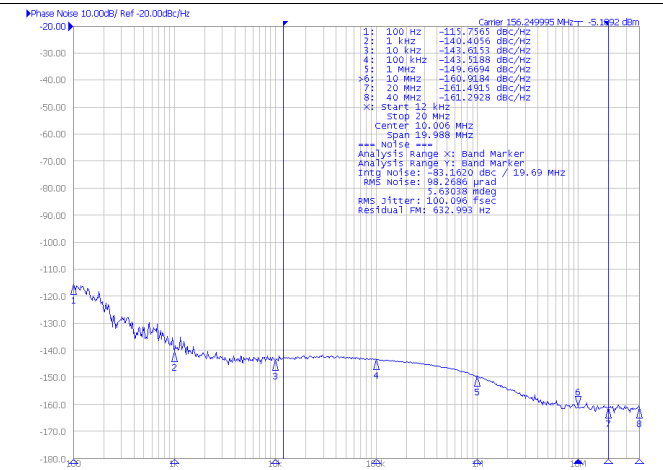

Figure 2. Phase Noise of LVDS Differential Output at 156.25 MHz with FS[1:0] = NC, NC, OS = NC

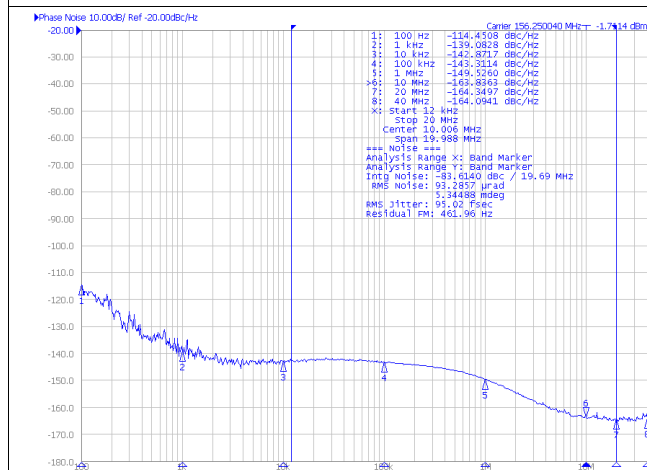

Figure 3. Phase Noise of HCSL Differential Output at 156.25 MHz with FS[1:0] = NC, NC, OS = VDD

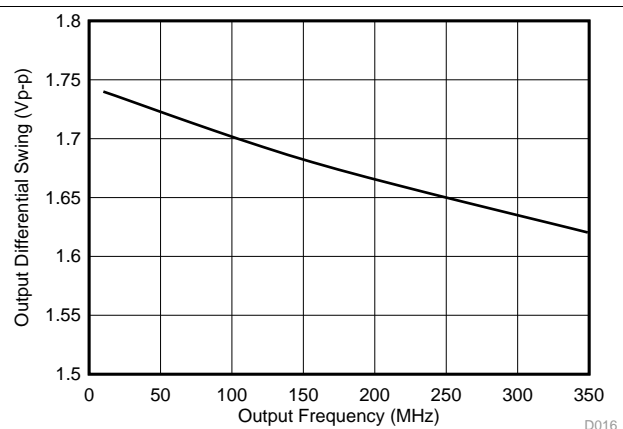

Figure 4. LVPECL Differential Output Swing vs Frequency

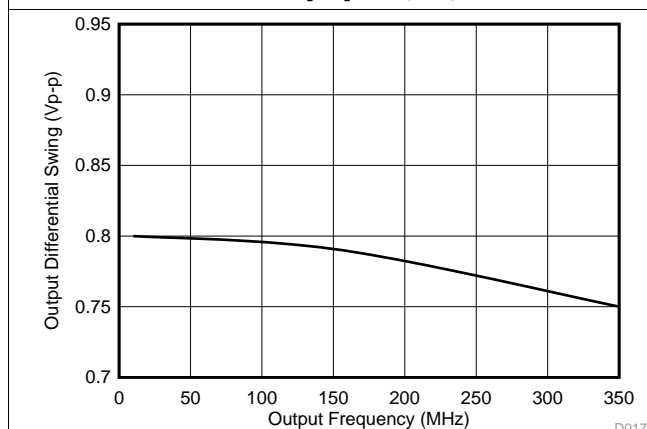

Figure 5. LVDS Differential Output Swing vs Frequency

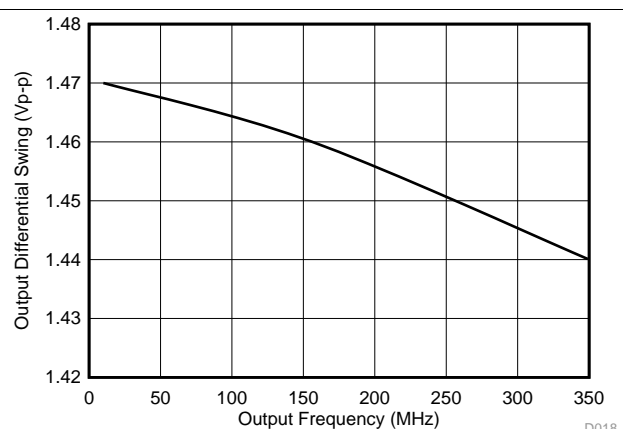

Figure 6. HCSL Differential Output Swing vs Frequency

8 Parameter Measurement Information

8.1 Device Output Configurations

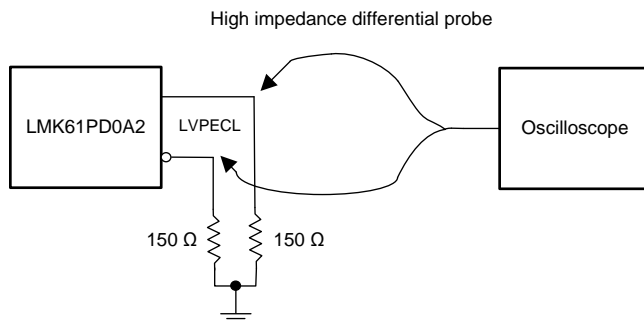

Figure 7. LVPECL Output DC Configuration during Device Test

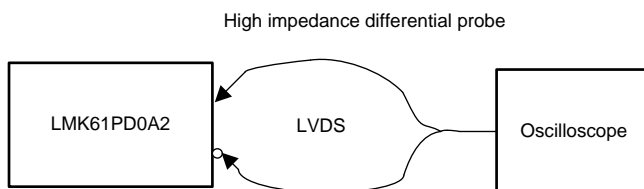

Figure 8. LVDS Output DC Configuration during Device Test

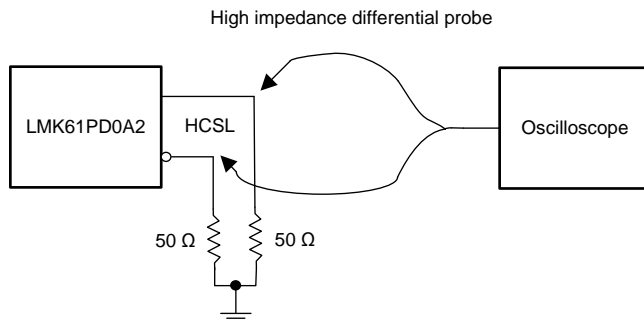

Figure 9. HCSL Output DC Configuration during Device Test

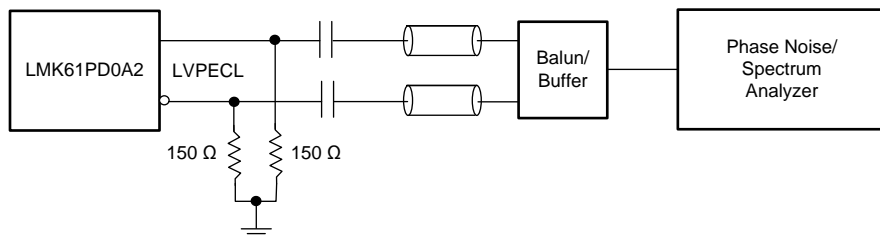

Figure 10. LVPECL Output AC Configuration during Device Test

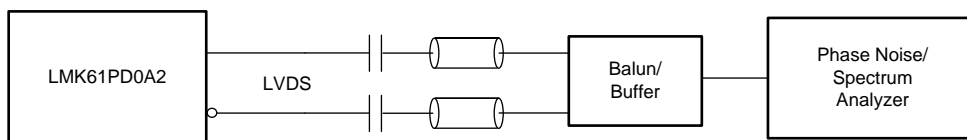

Figure 11. LVDS Output AC Configuration during Device Test

Device Output Configurations (continued)

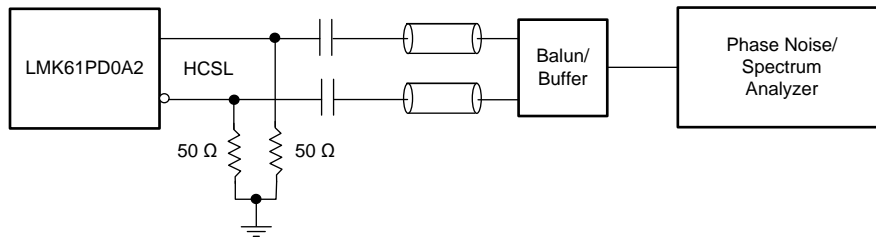

Figure 12. HCSL Output AC Configuration during Device Test

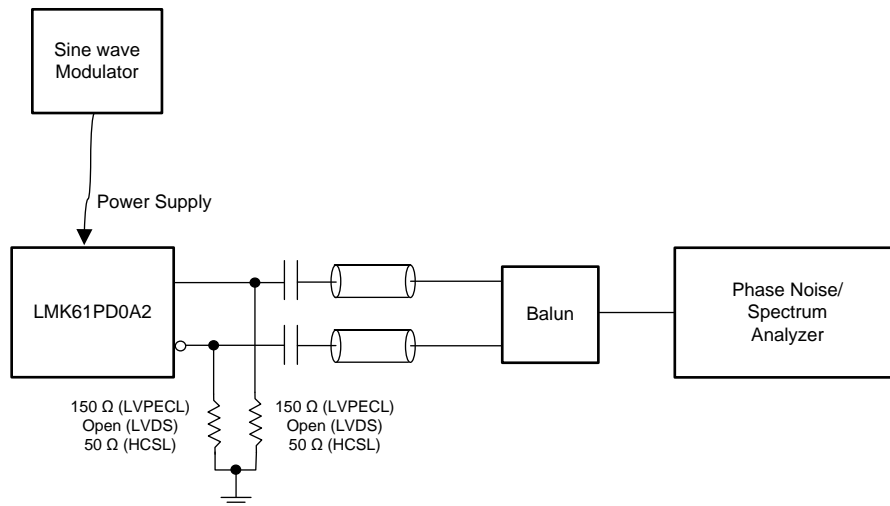

Figure 13. PSRR Test Setup

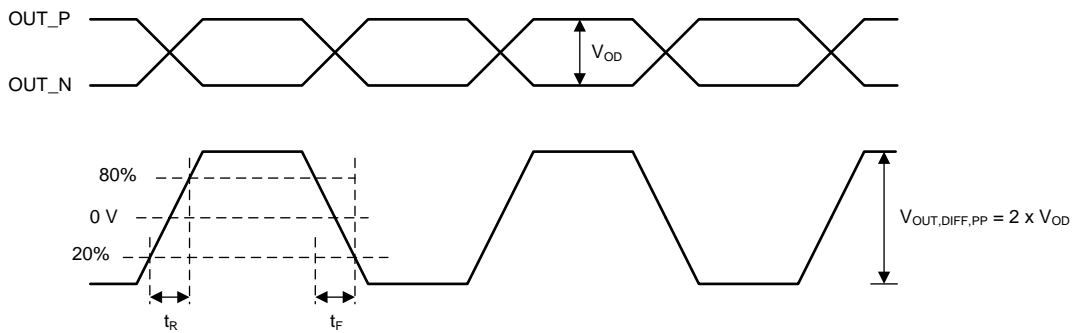

Figure 14. Differential Output Voltage and Rise/Fall Time

9 Detailed Description

9.1 Overview

The LMK61PD0A2 is a pin selectable oscillator that generates commonly used reference clocks, greater than 100 MHz, with less than 200 fs, rms max random jitter.

9.2 Functional Block Diagram

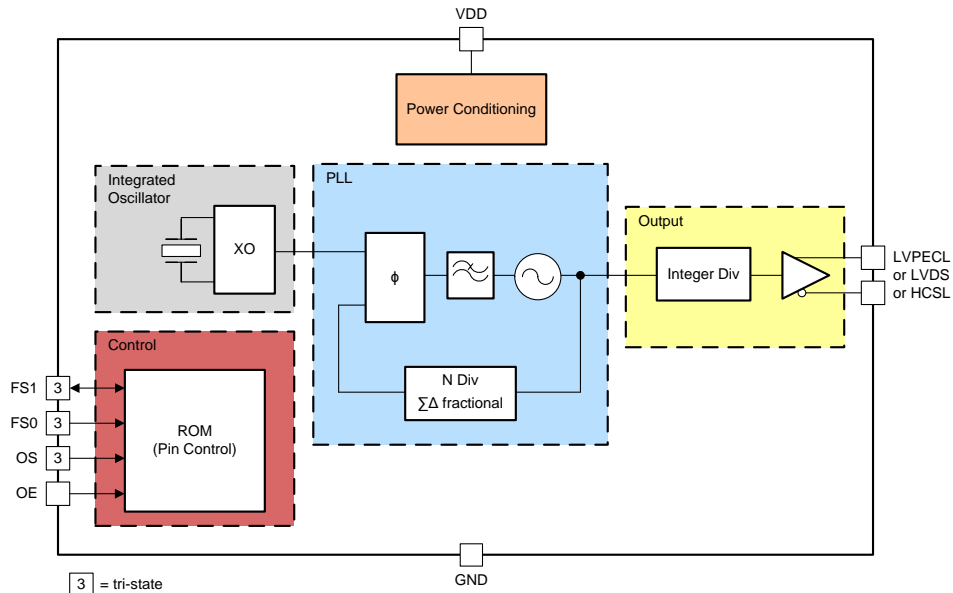

NOTE

Control blocks are compatible with 1.8/2.5/3.3 V I/O voltage levels.

9.3 Feature Description

9.3.1 Device Block-Level Description

The LMK61PD0A2 comprises of an integrated oscillator that includes a 50 MHz crystal, a fractional PLL with integrated VCO. Completing the device is the combination of an integer output divider and a universal differential output buffer. The on-chip ROM contains seven pre-programmed output frequency plans that selects the appropriate settings for the integrated oscillator, PLL blocks and output divider. [Table 1](#) lists the supported output frequency plans that can be selected by pin-strapping FS[1:0] as required. [Table 2](#) lists the supported output types that can be selected by pin-strapping OS and OE as required. The device is powered by on-chip low dropout (LDO) linear voltage regulators and the regulated supply network is partitioned such that the sensitive analog supplies are running from separate LDOs than the digital supplies which use their own LDO. The LDOs provide isolation from any noise in the external power supply rail with a PSRR of better than -70 dBc at 50 kHz to 1 MHz ripple frequencies at 3.3 V device supply.

9.3.2 Device Configuration Control

The LMK61PD0A2 selects an output frequency plan and output type using control pins FS[1:0].

10 Application and Implementation

NOTE

Information in the following applications sections is not part of the TI component specification, and TI does not warrant its accuracy or completeness. TI's customers are responsible for determining suitability of components for their purposes. Customers should validate and test their design implementation to confirm system functionality.

10.1 Application Information

The LMK61PD0A2 is an ultra-low jitter pin selectable oscillator that can be used to provide reference clocks for high-speed serial links resulting in improved system performance.

10.2 Typical Application

10.2.1 Jitter Considerations in Serdes Systems

Jitter-sensitive applications such as 10 Gbps or 100 Gbps Ethernet, deploy a serial link utilizing a Serializer in the transmit section (TX) and a De-serializer in the receive section (RX). These SERDES blocks are typically embedded in an ASIC or FPGA. Estimating the clock jitter impact on the link budget requires understanding of the TX PLL bandwidth and the RX CDR bandwidth.

As can be seen in [Figure 15](#), the pass band region between the TX low pass cutoff and RX high pass cutoff frequencies is the range over which the reference clock jitter adds without any attenuation to the jitter budget of the link. Outside of these frequencies, the SERDES link will attenuate the reference clock jitter with a 20 dB/dec or even steeper roll-off. Modern ASIC or FPGA designs have some flexibility on deciding the optimal RX CDR bandwidth and TX PLL bandwidth. These bandwidths are typically set based on what is achievable in the ASIC or FPGA process node, without increasing design complexity, and on any jitter tolerance or wander specification that needs to be met, as related to the RX CDR bandwidth.

The overall allowable jitter in a serial link is dictated by IEEE or other relevant standards. For example, IEEE802.3ba states that the maximum transmit jitter (peak-peak) for 10 Gbps Ethernet should be no more than $0.28 * UI$ and this equates to a 27.1516 ps, p-p for the overall allowable transmit jitter.

The jitter contributing elements are made up of the reference clock, generated potentially from a device like LMK61PD0A2, the transmit medium, transmit driver etc. Only a portion of the overall allowable transmit jitter is allocated to the reference clock, typically 20% or lower. Therefore, the allowable reference clock jitter, for a 20% clock jitter budget, is 5.43 ps, p-p.

Jitter in a reference clock is made up of deterministic jitter (arising from spurious signals due to supply noise or mixing from other outputs or from the reference input) and random jitter (usually due to thermal noise and other uncorrelated noise sources). A typical clock tree in a serial link system consists of clock generators and fanout buffers. The allowable reference clock jitter of 5.43 ps, p-p is needed at the output of the fanout buffer. Modern fanout buffers have low additive random jitter (less than 100 fs, rms) with no substantial contribution to the deterministic jitter. Therefore, the clock generator and fanout buffer contribute to the random jitter while the primary contributor to the deterministic jitter is the clock generator. Rule of thumb, for modern clock generators, is to allocate 25% of allowable reference clock jitter to the deterministic jitter and 75% to the random jitter. This amounts to an allowable deterministic jitter of 1.36 ps, p-p and an allowable random jitter of 4.07 ps, p-p. For serial link systems that need to meet a bit error rate (BER) of 10^{-12} , the allowable random jitter in root-mean-square is 0.29 ps, rms. This is calculated by dividing the p-p jitter by 14 for a BER of 10^{-12} . Accounting for random jitter from the fanout buffer, the random jitter needed from the clock generator is 0.27 ps, rms. This is calculated by the root-mean-square subtraction from the desired jitter at the fanout buffer's output assuming 100 fs, rms of additive jitter from the fanout buffer.

With careful frequency planning techniques, like spur optimization (covered in the Spur Mitigation Techniques section) and on-chip LDOs to suppress supply noise, the LMK61PD0A2 is able to generate clock outputs with deterministic jitter that is below 1 ps, p-p and random jitter that is below 0.2 ps, rms. This gives the serial link system with additional margin on the allowable transmit jitter resulting in a BER better than 10^{-12} .

Typical Application (continued)

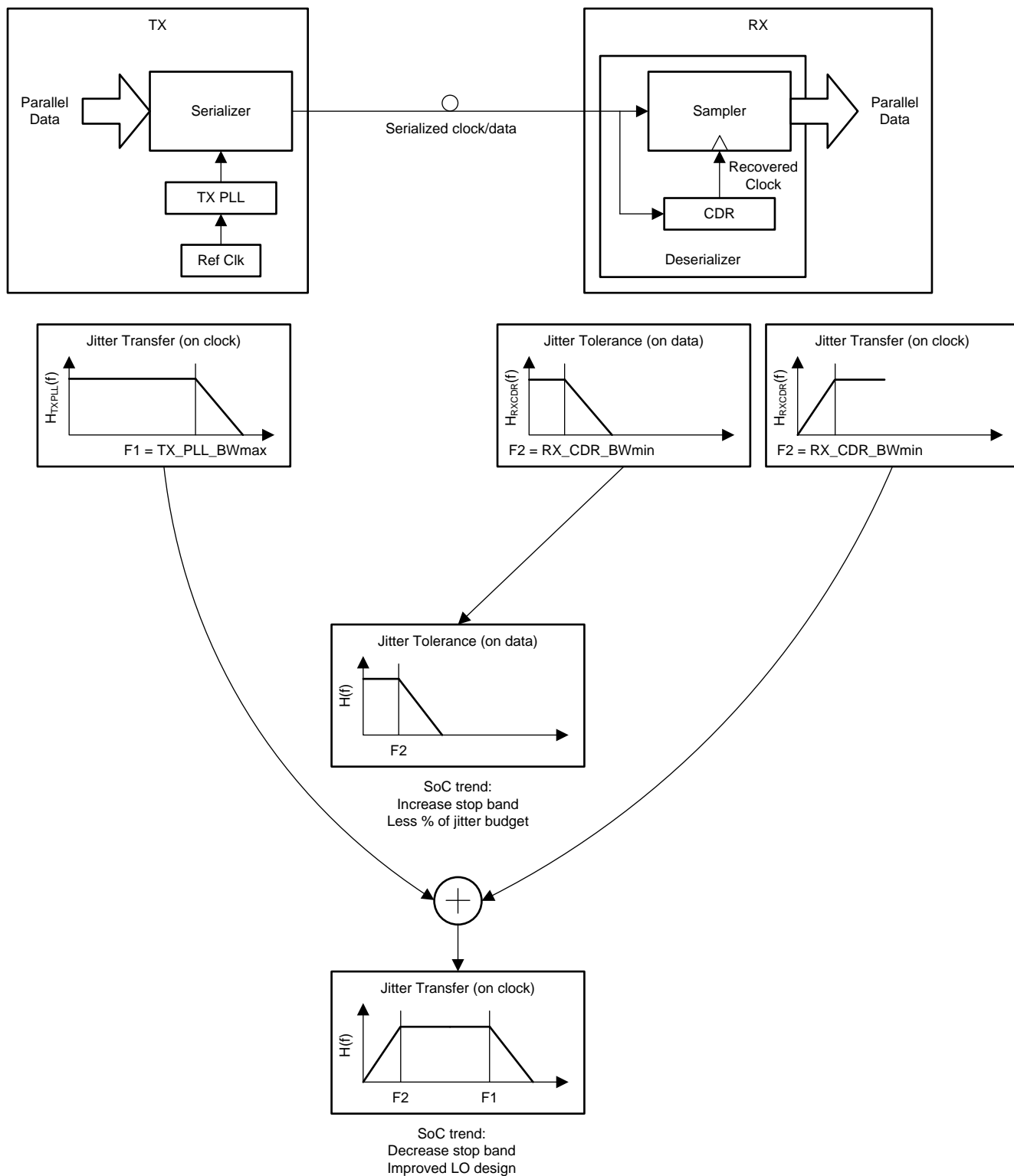

Figure 15. Dependence of Clock Jitter in Serial Links

11 Power Supply Recommendations

For best electrical performance of LMK61PD0A2, it is preferred to utilize a combination of 10 uF, 1 uF and 0.1 uF on its power supply bypass network. It is also recommended to utilize component side mounting of the power supply bypass capacitors and it is best to use 0201 or 0402 body size capacitors to facilitate signal routing. Keep the connections between the bypass capacitors and the power supply on the device as short as possible. Ground the other side of the capacitor using a low impedance connection to the ground plane. [Figure 16](#) shows the layout recommendation for power supply decoupling of LMK61PD0A2.

12 Layout

12.1 Layout Guidelines

The following sections provides recommendations for board layout, solder reflow profile and power supply bypassing when using LMK61PD0A2 to ensure good thermal / electrical performance and overall signal integrity of entire system.

12.1.1 Ensuring Thermal Reliability

The LMK61PD0A2 is a high performance device. Therefore careful attention must be paid to device configuration and printed circuit board (PCB) layout with respect to power consumption. The ground pin needs to be connected to the ground plane of the PCB through three vias or more, as shown in [Figure 16](#), to maximize thermal dissipation out of the package.

[Equation 1](#) describes the relationship between the PCB temperature around the LMK61PD0A2 and its junction temperature.

$$T_B = T_J - \Psi_{JB} * P$$

where

- T_B : PCB temperature around the LMK61PD0A2
 - T_J : Junction temperature of LMK61PD0A2
 - Ψ_{JB} : Junction-to-board thermal resistance parameter of LMK61PD0A2 (36.7°C/W without airflow)
 - P : On-chip power dissipation of LMK61PD0A2
- (1)

In order to ensure that the maximum junction temperature of LMK61PD0A2 is below 125°C, it can be calculated that the maximum PCB temperature without airflow should be at 100°C or below when the device is optimized for best performance resulting in maximum on-chip power dissipation of 0.68 W.

12.1.2 Best Practices for Signal Integrity

For best electrical performance and signal integrity of entire system with LMK61PD0A2, it is recommended to route vias into decoupling capacitors and then into the LMK61PD0A2. It is also recommended to increase the via count and width of the traces wherever possible. These steps ensure lowest impedance and shortest path for high frequency current flow. [Figure 16](#) shows the layout recommendation for LMK61PD0A2.

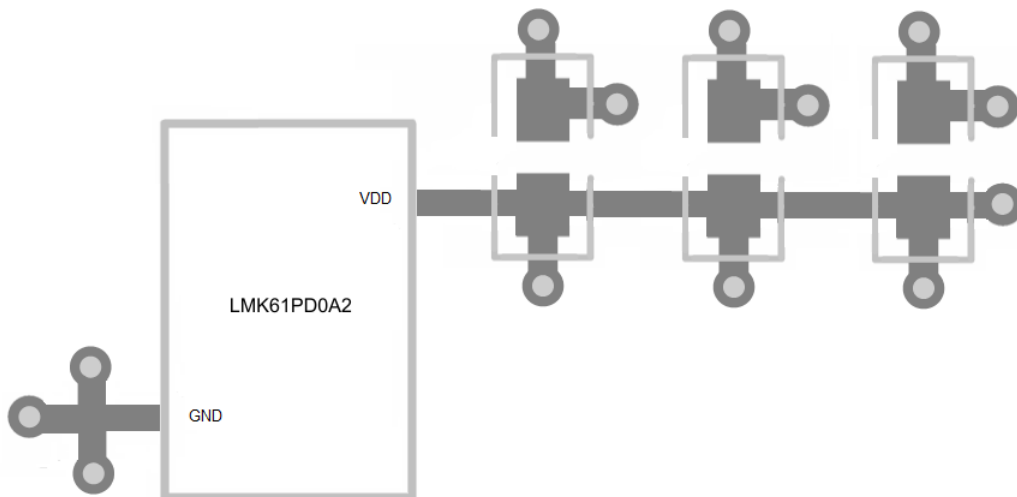

Figure 16. LMK61PD0A2 Layout Recommendation for Power Supply and Ground

Layout Guidelines (continued)

12.1.3 Recommended Solder Reflow Profile

It is recommended to follow the solder paste supplier's recommendations to optimize flux activity and to achieve proper melting temperatures of the alloy within the guidelines of J-STD-20. It is preferable for the LMK61PD0A2 to be processed with the lowest peak temperature possible while also remaining below the components peak temperature rating as listed on the MSL label. The exact temperature profile would depend on several factors including maximum peak temperature for the component as rated on the MSL label, Board thickness, PCB material type, PCB geometries, component locations, sizes, densities within PCB, as well solder manufactures recommended profile, and capability of the reflow equipment to as confirmed by the SMT assembly operation.

13 Device and Documentation Support

13.1 Community Resources

The following links connect to TI community resources. Linked contents are provided "AS IS" by the respective contributors. They do not constitute TI specifications and do not necessarily reflect TI's views; see TI's [Terms of Use](#).

TI E2E™ Online Community *TI's Engineer-to-Engineer (E2E) Community*. Created to foster collaboration among engineers. At e2e.ti.com, you can ask questions, share knowledge, explore ideas and help solve problems with fellow engineers.

Design Support *TI's Design Support* Quickly find helpful E2E forums along with design support tools and contact information for technical support.

13.2 Trademarks

E2E is a trademark of Texas Instruments.

13.3 Electrostatic Discharge Caution



These devices have limited built-in ESD protection. The leads should be shorted together or the device placed in conductive foam during storage or handling to prevent electrostatic damage to the MOS gates.

13.4 Glossary

[SLYZ022](#) — *TI Glossary*.

This glossary lists and explains terms, acronyms, and definitions.

14 Mechanical, Packaging, and Orderable Information

The following pages include mechanical, packaging, and orderable information. This information is the most current data available for the designated devices. This data is subject to change without notice and revision of this document. For browser-based versions of this data sheet, refer to the left-hand navigation.

PACKAGING INFORMATION

Orderable Device	Status (1)	Package Type	Package Drawing	Pins	Package Qty	Eco Plan (2)	Lead/Ball Finish (6)	MSL Peak Temp (3)	Op Temp (°C)	Device Marking (4/5)	Samples
LMK61PD0A2-SIAR	ACTIVE	QFM	SIA	8	2500	Green (RoHS & no Sb/Br)	Call TI NIAU	Level-3-260C-168 HR	-40 to 85	LMK61 PD0A2	Samples
LMK61PD0A2-SIAT	ACTIVE	QFM	SIA	8	250	Green (RoHS & no Sb/Br)	Call TI NIAU	Level-3-260C-168 HR	-40 to 85	LMK61 PD0A2	Samples

(1) The marketing status values are defined as follows:

ACTIVE: Product device recommended for new designs.

LIFEBUY: TI has announced that the device will be discontinued, and a lifetime-buy period is in effect.

NRND: Not recommended for new designs. Device is in production to support existing customers, but TI does not recommend using this part in a new design.

PREVIEW: Device has been announced but is not in production. Samples may or may not be available.

OBSOLETE: TI has discontinued the production of the device.

(2) Eco Plan - The planned eco-friendly classification: Pb-Free (RoHS), Pb-Free (RoHS Exempt), or Green (RoHS & no Sb/Br) - please check <http://www.ti.com/productcontent> for the latest availability information and additional product content details.

TBD: The Pb-Free/Green conversion plan has not been defined.

Pb-Free (RoHS): TI's terms "Lead-Free" or "Pb-Free" mean semiconductor products that are compatible with the current RoHS requirements for all 6 substances, including the requirement that lead not exceed 0.1% by weight in homogeneous materials. Where designed to be soldered at high temperatures, TI Pb-Free products are suitable for use in specified lead-free processes.

Pb-Free (RoHS Exempt): This component has a RoHS exemption for either 1) lead-based flip-chip solder bumps used between the die and package, or 2) lead-based die adhesive used between the die and leadframe. The component is otherwise considered Pb-Free (RoHS compatible) as defined above.

Green (RoHS & no Sb/Br): TI defines "Green" to mean Pb-Free (RoHS compatible), and free of Bromine (Br) and Antimony (Sb) based flame retardants (Br or Sb do not exceed 0.1% by weight in homogeneous material)

(3) MSL, Peak Temp. - The Moisture Sensitivity Level rating according to the JEDEC industry standard classifications, and peak solder temperature.

(4) There may be additional marking, which relates to the logo, the lot trace code information, or the environmental category on the device.

(5) Multiple Device Markings will be inside parentheses. Only one Device Marking contained in parentheses and separated by a "~" will appear on a device. If a line is indented then it is a continuation of the previous line and the two combined represent the entire Device Marking for that device.

(6) Lead/Ball Finish - Orderable Devices may have multiple material finish options. Finish options are separated by a vertical ruled line. Lead/Ball Finish values may wrap to two lines if the finish value exceeds the maximum column width.

Important Information and Disclaimer: The information provided on this page represents TI's knowledge and belief as of the date that it is provided. TI bases its knowledge and belief on information provided by third parties, and makes no representation or warranty as to the accuracy of such information. Efforts are underway to better integrate information from third parties. TI has taken and continues to take reasonable steps to provide representative and accurate information but may not have conducted destructive testing or chemical analysis on incoming materials and chemicals. TI and TI suppliers consider certain information to be proprietary, and thus CAS numbers and other limited information may not be available for release.

In no event shall TI's liability arising out of such information exceed the total purchase price of the TI part(s) at issue in this document sold by TI to Customer on an annual basis.

TAPE AND REEL INFORMATION

QUADRANT ASSIGNMENTS FOR PIN 1 ORIENTATION IN TAPE



*All dimensions are nominal

Device	Package Type	Package Drawing	Pins	SPQ	Reel Diameter (mm)	Reel Width W1 (mm)	A0 (mm)	B0 (mm)	K0 (mm)	P1 (mm)	W (mm)	Pin1 Quadrant
LMK61PD0A2-SIAR	QFM	SIA	8	2500	330.0	16.4	5.5	7.5	1.5	8.0	16.0	Q1
LMK61PD0A2-SIAT	QFM	SIA	8	250	178.0	16.4	5.5	7.5	1.5	8.0	16.0	Q1

TAPE AND REEL BOX DIMENSIONS

*All dimensions are nominal

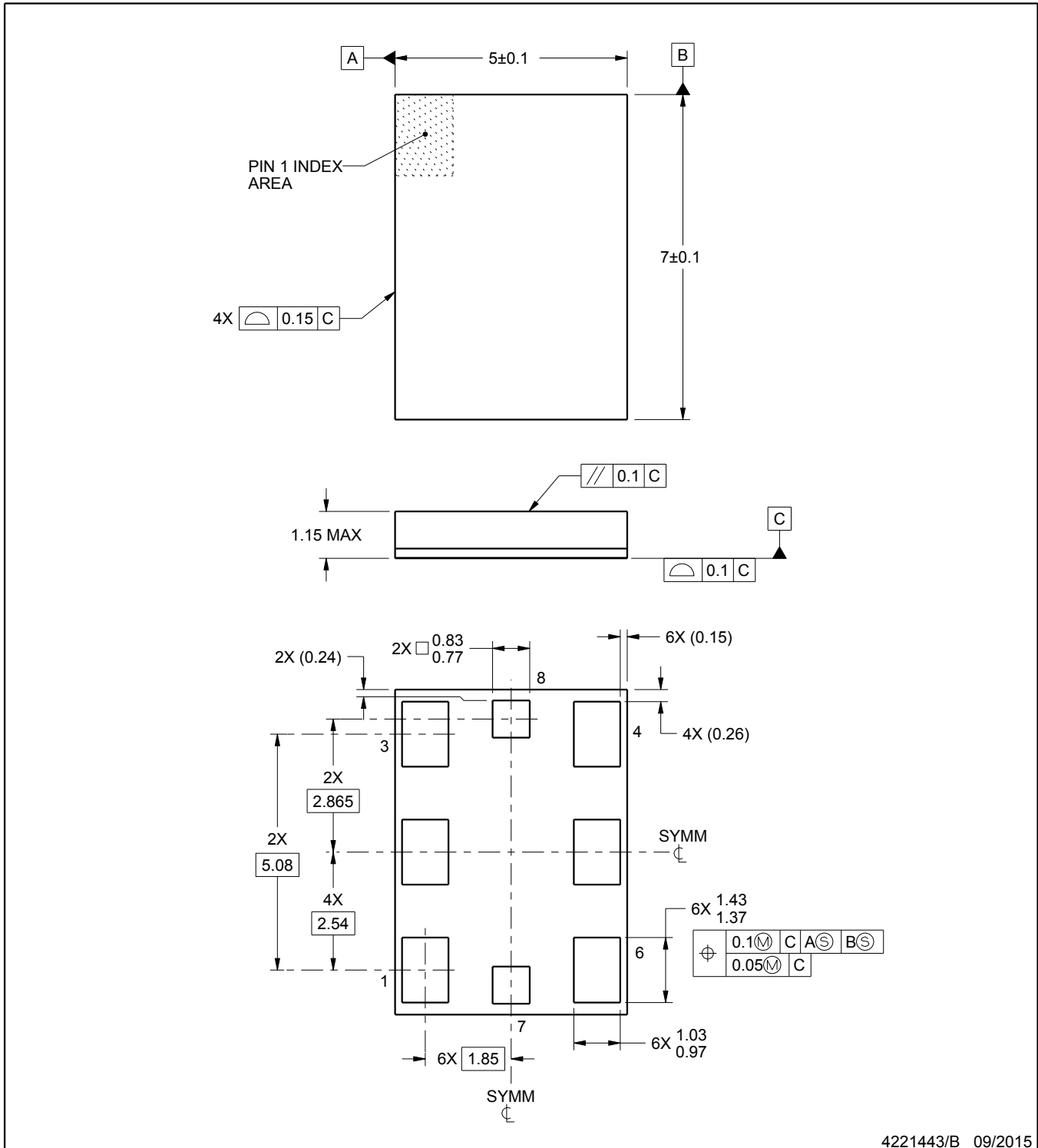
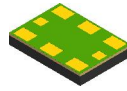
Device	Package Type	Package Drawing	Pins	SPQ	Length (mm)	Width (mm)	Height (mm)
LMK61PD0A2-SIAR	QFM	SIA	8	2500	367.0	367.0	38.0
LMK61PD0A2-SIAT	QFM	SIA	8	250	210.0	185.0	35.0



4221443/B 09/2015

NOTES:

1. All linear dimensions are in millimeters. Any dimensions in parenthesis are for reference only. Dimensioning and tolerancing per ASME Y14.5M.
2. This drawing is subject to change without notice.

EXAMPLE BOARD LAYOUT

SIA0008B

QFM - 1.15 mm max height

QUAD FLAT MODULE

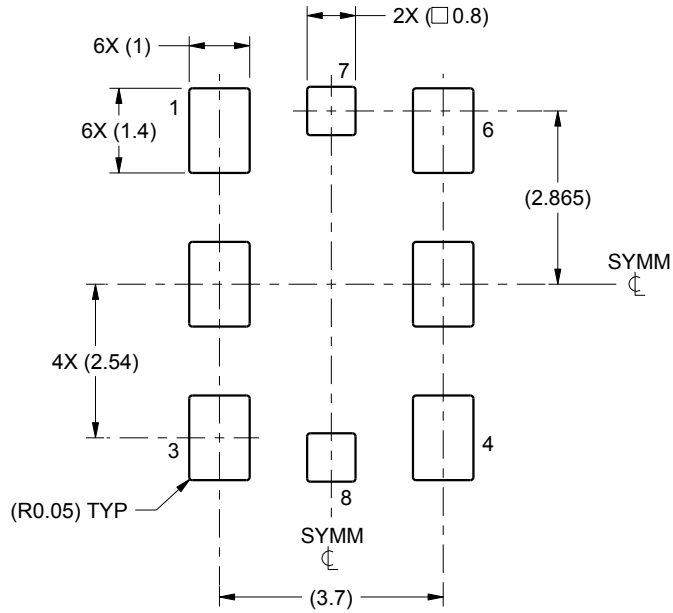

LAND PATTERN EXAMPLE
1:1 RATIO WITH PACKAGE SOLDER PADS
SCALE:8X

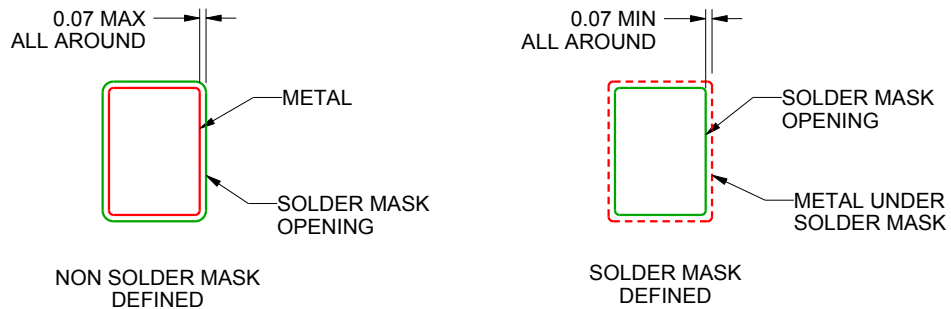

SOLDER MASK DETAILS
NOT TO SCALE

4221443/B 09/2015

NOTES: (continued)

3. For more information, see Texas Instruments literature number SLUA271 (www.ti.com/lit/sluea271).

EXAMPLE STENCIL DESIGN

SIA0008B

QFM - 1.15 mm max height

QUAD FLAT MODULE

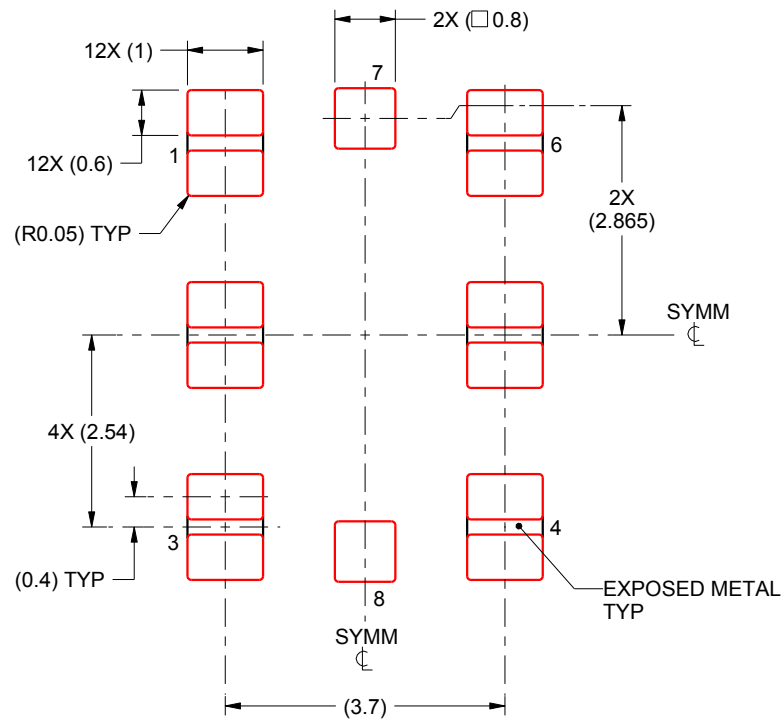

SOLDER PASTE EXAMPLE
BASED ON 0.125 mm THICK STENCIL
PRINTED SOLDER COVERAGE BY AREA
PADS 1-3 & 4-6: 86%
SCALE:10X

4221443/B 09/2015

NOTES: (continued)

4. Laser cutting apertures with trapezoidal walls and rounded corners may offer better paste release. IPC-7525 may have alternate design recommendations.

IMPORTANT NOTICE

Texas Instruments Incorporated and its subsidiaries (TI) reserve the right to make corrections, enhancements, improvements and other changes to its semiconductor products and services per JESD46, latest issue, and to discontinue any product or service per JESD48, latest issue. Buyers should obtain the latest relevant information before placing orders and should verify that such information is current and complete. All semiconductor products (also referred to herein as "components") are sold subject to TI's terms and conditions of sale supplied at the time of order acknowledgment.

TI warrants performance of its components to the specifications applicable at the time of sale, in accordance with the warranty in TI's terms and conditions of sale of semiconductor products. Testing and other quality control techniques are used to the extent TI deems necessary to support this warranty. Except where mandated by applicable law, testing of all parameters of each component is not necessarily performed.

TI assumes no liability for applications assistance or the design of Buyers' products. Buyers are responsible for their products and applications using TI components. To minimize the risks associated with Buyers' products and applications, Buyers should provide adequate design and operating safeguards.

TI does not warrant or represent that any license, either express or implied, is granted under any patent right, copyright, mask work right, or other intellectual property right relating to any combination, machine, or process in which TI components or services are used. Information published by TI regarding third-party products or services does not constitute a license to use such products or services or a warranty or endorsement thereof. Use of such information may require a license from a third party under the patents or other intellectual property of the third party, or a license from TI under the patents or other intellectual property of TI.

Reproduction of significant portions of TI information in TI data books or data sheets is permissible only if reproduction is without alteration and is accompanied by all associated warranties, conditions, limitations, and notices. TI is not responsible or liable for such altered documentation. Information of third parties may be subject to additional restrictions.

Resale of TI components or services with statements different from or beyond the parameters stated by TI for that component or service voids all express and any implied warranties for the associated TI component or service and is an unfair and deceptive business practice. TI is not responsible or liable for any such statements.

Buyer acknowledges and agrees that it is solely responsible for compliance with all legal, regulatory and safety-related requirements concerning its products, and any use of TI components in its applications, notwithstanding any applications-related information or support that may be provided by TI. Buyer represents and agrees that it has all the necessary expertise to create and implement safeguards which anticipate dangerous consequences of failures, monitor failures and their consequences, lessen the likelihood of failures that might cause harm and take appropriate remedial actions. Buyer will fully indemnify TI and its representatives against any damages arising out of the use of any TI components in safety-critical applications.

In some cases, TI components may be promoted specifically to facilitate safety-related applications. With such components, TI's goal is to help enable customers to design and create their own end-product solutions that meet applicable functional safety standards and requirements. Nonetheless, such components are subject to these terms.

No TI components are authorized for use in FDA Class III (or similar life-critical medical equipment) unless authorized officers of the parties have executed a special agreement specifically governing such use.

Only those TI components which TI has specifically designated as military grade or "enhanced plastic" are designed and intended for use in military/aerospace applications or environments. Buyer acknowledges and agrees that any military or aerospace use of TI components which have **not** been so designated is solely at the Buyer's risk, and that Buyer is solely responsible for compliance with all legal and regulatory requirements in connection with such use.

TI has specifically designated certain components as meeting ISO/TS16949 requirements, mainly for automotive use. In any case of use of non-designated products, TI will not be responsible for any failure to meet ISO/TS16949.

Products

Audio	www.ti.com/audio
Amplifiers	amplifier.ti.com
Data Converters	dataconverter.ti.com
DLP® Products	www.dlp.com
DSP	dsp.ti.com
Clocks and Timers	www.ti.com/clocks
Interface	interface.ti.com
Logic	logic.ti.com
Power Mgmt	power.ti.com
Microcontrollers	microcontroller.ti.com
RFID	www.ti-rfid.com
OMAP Applications Processors	www.ti.com/omap
Wireless Connectivity	www.ti.com/wirelessconnectivity

Applications

Automotive and Transportation	www.ti.com/automotive
Communications and Telecom	www.ti.com/communications
Computers and Peripherals	www.ti.com/computers
Consumer Electronics	www.ti.com/consumer-apps
Energy and Lighting	www.ti.com/energy
Industrial	www.ti.com/industrial
Medical	www.ti.com/medical
Security	www.ti.com/security
Space, Avionics and Defense	www.ti.com/space-avionics-defense
Video and Imaging	www.ti.com/video

TI E2E Community

e2e.ti.com