

# 2 A Non-isolated Buck Converter Module MPM80 Series

## Data Sheet

### Description

MPM series is hybrid module ICs that include a non-isolated buck converter circuit with an inductor in a full-mold package. These features achieve simple circuit using few components, and reduce design cost and PCB space.

### Features

- Few external components realize reducing design and assembly cost.  
(Built-in inductor and phase compensation circuit)
- Easy to mount heatsink by full-molded package
- Two types of lead forming  
Upright angle for realizing mount area saving:  
Right angle for low profile mounting
- PWM synchronous rectification
- Wide input voltage range and high efficiency
- Protection:  
Overcurrent Protection: Pulse-by-pulse  
Overvoltage Protection: Latch  
Thermal Shutdown: Auto-restart

### Typical Application

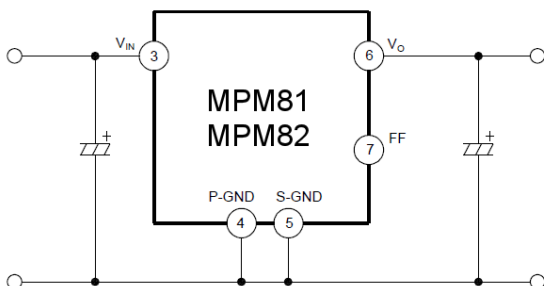
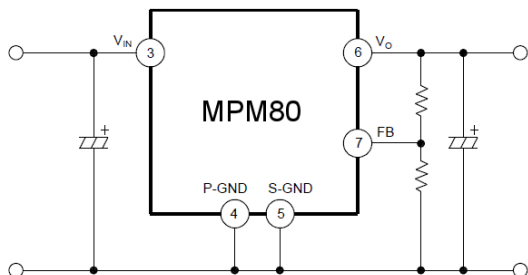

### Package

TO220F-8L



(Upright angle)

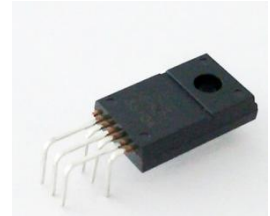

(Right angle)

Not to scale.

### MPM80 Series

Products	V <sub>O</sub> (V)	Order No.	Lead Formings
MPM80	3V to 16V	MPM80	Upright angle
		MPM80-R	Right angle
MPM81	3.3V (Fixed-output)	MPM81	Upright angle
		MPM81-R	Right angle
MPM82	5.0V (Fixed-output)	MPM82	Upright angle
		MPM82-R	Right angle

### Specifications

- Input voltage, V<sub>IN</sub> = 8V to 30V
- Maximum output current, I<sub>O</sub> = 2A
- Operating frequency, 630kHz

### Applications

- Factory automation equipment
- Communication equipment
- Consumer equipment
- Another DC/DC power supply circuit

## Contents

Description .....	1
Contents .....	2
1. Absolute Maximum Ratings .....	3
2. Recommended Operating Condition .....	3
3. Electrical Characteristics .....	4
4. Block Diagram .....	5
5. Pin Configuration Definitions .....	6
6. Typical Application .....	8
7. External Dimensions .....	10
8. Marking Diagram .....	12
9. Operational Description .....	13
9.1 Startup and Stop .....	13
9.2 Overcurrent Protection .....	13
9.3 Overvoltage Protection .....	13
9.4 Thermal Shutdown .....	13
10. Design Notes .....	13
10.1 Derating Curve .....	13
10.2 External Components .....	14
10.2.1 Input Smoothing Capacitor $C_{IN}$ .....	14
10.2.2 Output Smoothing Capacitor $C_{OUT}$ .....	14
10.2.3 Output Voltage Setup Resistor (for MPM80) .....	14
10.3 PCB Layout .....	15
11. Pattern Layout .....	16
12. Electrical Characteristics .....	17
12.1 MPM80 .....	17
12.2 MPM81 .....	18
12.3 MPM82 .....	19
IMPORTANT NOTES .....	20

## MPM80 Series

### 1. Absolute Maximum Ratings

Unless otherwise specified,  $T_A = 25\text{ }^\circ\text{C}$

Parameter	Symbol	Test Conditions	Rating	Units
Voltage Between VIN and GND Pins	$V_{IN}$	Short between P-GND and S-GND.	35	V
Voltage Between FB and GND Pins	$V_{FB}$	Short between P-GND and S-GND	5	V
Voltage Between VO and GND Pins	$V_O$	Short between P-GND and S-GND	20	V
MIC Capacity Loss	$P_{LOSS}$	Without a heatsink	2	W
Junction Temperature	$T_j$		-20 to 125	$^\circ\text{C}$
Storage Temperature	$T_{stg}$		-20 to 125	$^\circ\text{C}$
Thermal Resistance*	$\theta_{j-A}$	Without a heatsink	50	$^\circ\text{C}/\text{W}$

\*Between MIC junction and ambient.

### 2. Recommended Operating Condition

Recommended operating conditions refer to operating conditions to maintain normal circuit functions specified in the Electrical Characteristics table in this document and they must be followed in actual use.

See Typical Application for circuit connection.

Characteristic	Symbol	Min.	Max.	Unit	Conditions
Input Voltage Range	$V_{IN}$	8 <sup>(1)</sup>	30	V	
Output Voltage Range	$V_O$	3	16	V	MPM80 only
Output Current Range <sup>(2)</sup>	$I_O$	0	2	A	
Operating Junction Temperature <sup>(2)</sup>	$T_{j,OP}$	-20	125	$^\circ\text{C}$	
Operating Temperature Range	$T_A$	-20	85	$^\circ\text{C}$	Derating is required

<sup>(1)</sup> Minimum value must be either 8 V or  $V_O + 3\text{ V}$ , whichever is larger.

<sup>(2)</sup> Derating is required (see Section 10.1).

## MPM80 Series

### 3. Electrical Characteristics

Unless otherwise specified,  $T_A = 25\text{ }^\circ\text{C}$ ,  $V_{IN} = 12\text{ V}$

The Electrical Characteristics refer to characteristics value specification in the typical circuit shown in Section 6 when the IC operates under conditions in this document.

Parameter	Symbol	Test Conditions	Min.	Typ.	Max.	Units	Notes
Output Voltage Setting Reference Voltage	$V_{FB\_REF}$	$I_O = 1\text{ A}$	0.792	0.800	0.808	V	MPM80
Setup Output Voltage	$V_{O\_REF}$	$V_{IN} = 8\text{ V to }30\text{ V}$ $I_O = 1\text{ A}$	3.230	3.300	3.370	V	MPM81
		$V_{IN} = 8\text{ V to }30\text{ V}$ $I_O = 1\text{ A}$	4.900	5.000	5.100	V	MPM82
Output Voltage Setting Reference Voltage Temperature Coefficient	$\Delta V_{FB\_REF}/\Delta T$	$T_A = -20\text{ to }85\text{ }^\circ\text{C}$		$\pm 0.05$		mV/ $^\circ\text{C}$	MPM80
Line Regulation <sup>(1)</sup>	$V_{LINE}$	$V_{IN} = 8\text{ V to }30\text{ V}$ $I_O = 1\text{ A}$ $V_O = 5.0\text{ V (MPM80)}$	-2	-	2	%	
Operating Frequency	f		567	630	693	kHz	
Load Regulation <sup>(1)</sup>	$V_{LOAD}$	$I_O = 0\text{ to }2\text{ A}$ $V_O = 5.0\text{ V (MPM80)}$	-3	-	3	%	
Overcurrent Protection Starting Current <sup>(2)</sup>	$I_S$	Drooping, Auto restart $V_O = 5.0\text{ V (MPM80)}$	2.4	-	4.0	A	
Supply Current	$I_{IN}$	$I_O = 0\text{ A}$ $V_{FB} = 1\text{ V}$	-	2.5	-	mA	
Overvoltage Protection Starting Voltage <sup>(3)</sup>	$V_{OVP}$	$V_{IN} = 8\text{ V to }35\text{ V}$	-	1.1 $\times V_{FB\_REF}$	-	V	MPM80
			-	1.1 $\times V_{O\_REF}$	-	V	MPM81 MPM82
MIC Thermal Shut-down Stating Temperature <sup>(4)</sup>	$T_{J\_TSD}$	$V_{IN} = 8\text{ V to }35\text{ V}$	135	150	-	$^\circ\text{C}$	
Under Voltage Lockout (UVLO) Voltage	UVLO		6.0	7.0	7.5	V	
UVLO Release Threshold	UVLO(OFF)		5.5	6.5	7.0	V	
UVLO Hysteresis Voltage <sup>(3)</sup>	UVLO(HYS)		-	0.5	-	V	
Minimum Input-Output Difference	$V_{IN}-V_{O(MIN)}$	$V_O = 12\text{ V}$	3	-	-	V	
Minimum Settable Output Voltage	$V_{O(MIN)}$	$V_{IN} = 30\text{ V}$	-	3	-	V	MPM80
Internal Soft-Start Timer <sup>(3)</sup>	$t_{SS}$	$V_{IN} = 12\text{ V}$ $I_O = 1\text{ A}$	-	6.4	-	ms	
Maximum ON Duty <sup>(3)</sup>	$D_{MAX}$		-	90	-	%	
Minimum ON Time <sup>(3)</sup>	$t_{MIN}$		-	160	-	ns	
Inductance Value	L		4.48	5.6	6.72	$\mu\text{H}$	

<sup>(1)</sup>In the MPM80, line regulation and load regulation do not include the setup deviation of output voltage.

The output voltage setup deviation is influenced by the resistance variation of external R1 and R2. See Section 6 Typical Application Circuit for details.

<sup>(2)</sup>In the MPM80, if the output voltage  $V_O$ , is set to any value other than 5.0 V, OCP operating point may vary significantly because the internal inductor's inductance and the operating frequency are fixed.

<sup>(3)</sup>Determined by design.

<sup>(4)</sup>Thermal shutdown is auto-restart.

4. Block Diagram

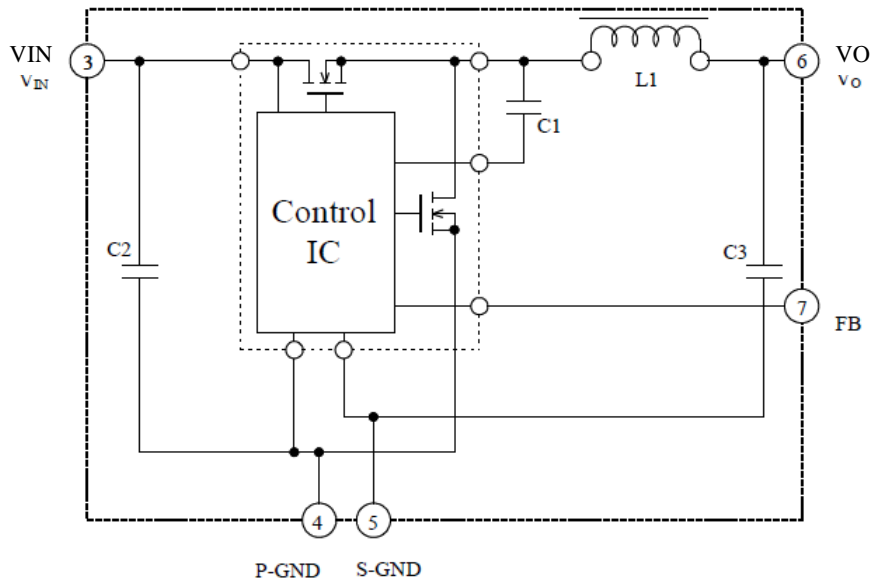

Figure 4-1 MPM80 block diagram

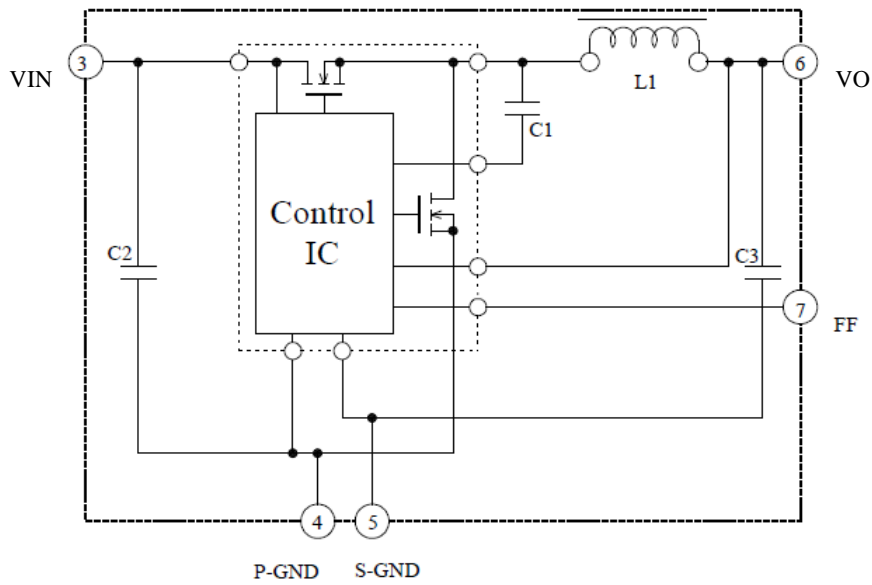

Figure 4-2 MPM81 and MPM82 block diagram

5. Pin Configuration Definitions

Figure 5-1 MPM80



Pin	Name	Descriptions
1	—	Lead has been cut <sup>(1)</sup>
2	NC	No connection
3	VIN	Input pin for power source Connect the input smoothing capacitor $C_{IN}$
4	P-GND	Power ground pin
5	S-GND	Signal ground pin
6	VO	Output pin Connect the output smoothing capacitor $C_{OUT}$
7	FB	Output voltage feedback pin Connect the dividing resistors R1, R2 in Typical Application
8	—	Pin was pulled out <sup>(2)</sup>

Figure 5-2 MPM81, MPM82



Pin	Name	Descriptions
1	—	Lead has been cut <sup>(1)</sup>
2	NC	No connection
3	VIN	Input pin for power source Connect the input smoothing capacitor $C_{IN}$
4	P-GND	Power ground pin
5	S-GND	Signal ground pin
6	VO	Output pin Connect the output smoothing capacitor $C_{OUT}$
7	FF	Feed forward pin Phase compensation capacitor, $C_p$ , is connected between $V_O$ and FF when a ceramic capacitor is used for $C_{OUT}$ .
8	—	Pin was pulled out <sup>(2)</sup>

<sup>(1)</sup>1 pin is not the function pin but the test pin to measure the oscillation frequency. Therefore 1mm of pin remains though it is cut off at the root of pin after test. Since the remained pin is live part, please pay attention to avoid the connection of the remained pin and the other live part pattern.( Figure 5-1)

<sup>(2)</sup>8 pin is pulled out for this product. The burr sticks out in the 8 pin position.

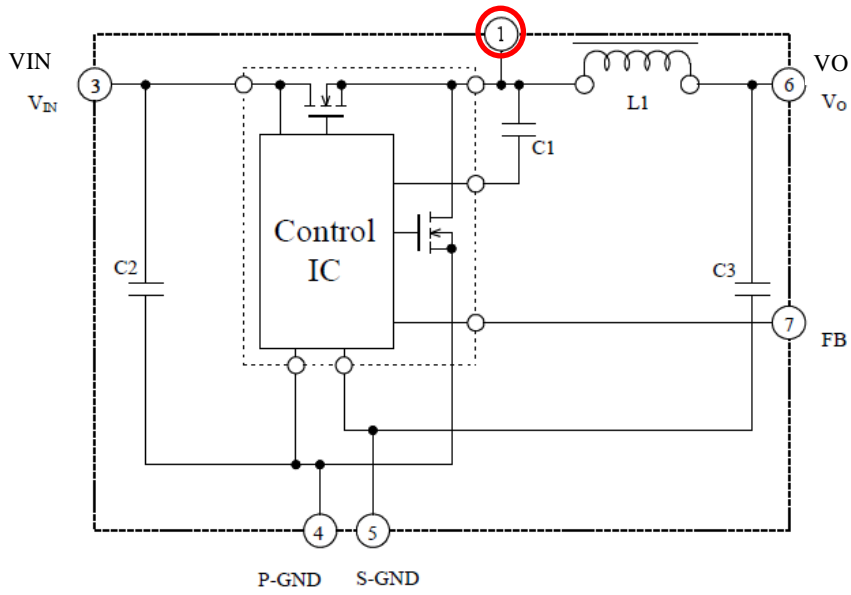

Figure 5-1 Internal connection of 1 pin

6. Typical Application

Figure 6-1 and Figure 6-2 show the typical circuit of the MPM80, MPM81 and MPM82. Table 6-1 shows the recommended circuit parameter.

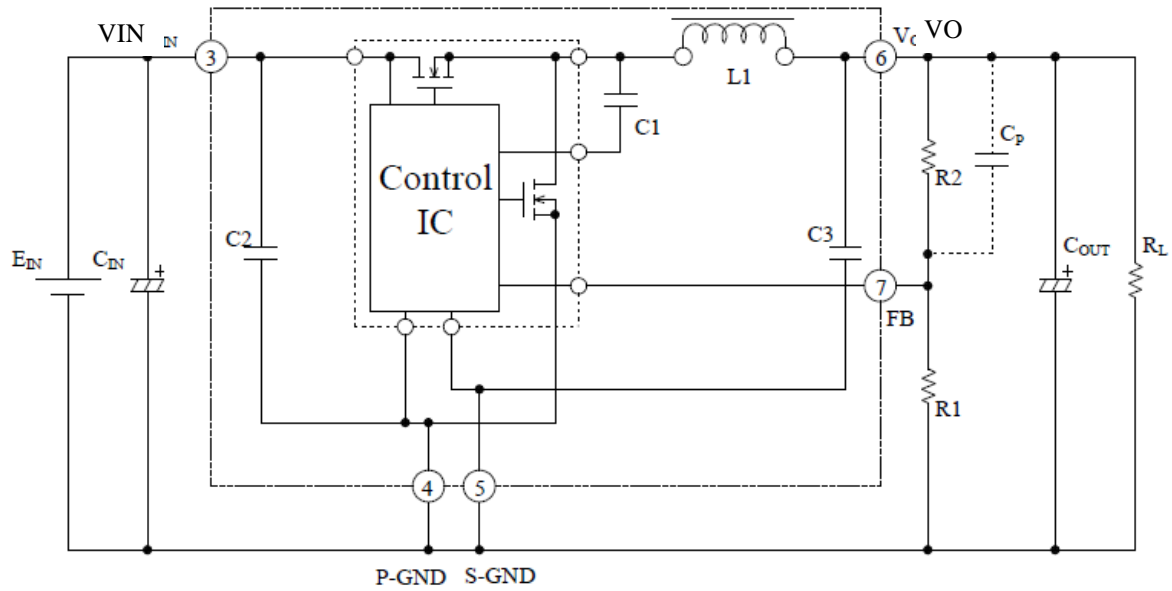

Figure 6-1 MPM80

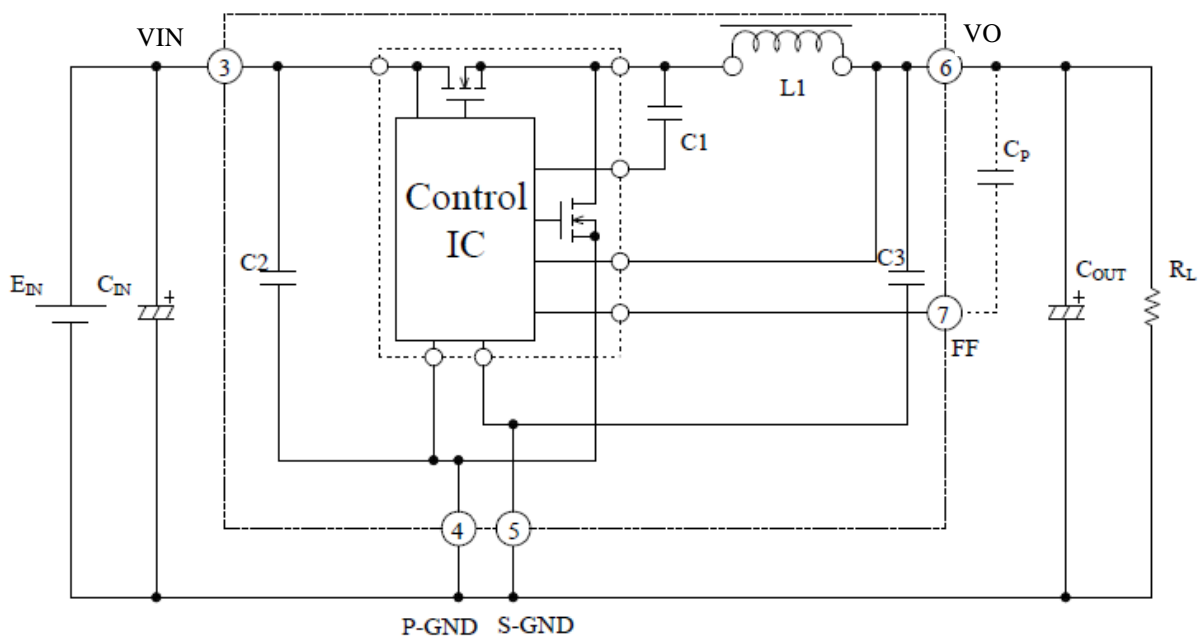

Figure 6-2 MPM81 and MPM82



Table 6-1 Recommended circuit parameter

Symbol	Parameters	Constant Information	Notes
$E_{IN}$	Source of input voltage	8 V to 30 V	
$C_{IN}$	Input smoothing capacitor	100 $\mu$ F to 1000 $\mu$ F	$C_{IN}$ is not required if the input voltage is stable. If operation is unstable, add a bypass capacitor (about 1 $\mu$ F, ceramic) as near as possible to the device, between $V_{IN}$ and GND pins.
$C_{OUT}$	Output smoothing capacitor	Electrolytic capacitor is 220 $\mu$ F to 1000 $\mu$ F. Ceramic capacitor is 47 $\mu$ F to 100 $\mu$ F.	A low-impedance capacitor should be used for switching power supply when using an electrolytic capacitor
R1	Output voltage setup resistor	680 $\Omega$ to 1.5 k $\Omega$	It is required only for MPM80. It is not necessary for MPM81 and MPM82.
R2	Output voltage setup resistor		Resistance value is set according to the desired output voltage. R2 is calculated by the Equation (1). It is required only for MPM80. It is not required for MPM81 and MPM82.
$C_P$	Phase compensation capacitor	100 pF to 470 pF	$C_P$ is required when using a ceramic capacitor for $C_{OUT}$ .
$R_L$	Load		Load is connected to the subsequent $C_{OUT}$ .

$$R2 = \left( \frac{V_O}{V_{FB\_REF}} - 1 \right) \times R1 \quad (1)$$

where

$V_O$ : Target output voltage (V)

$V_{FB\_REF}$ : FB pin reference voltage (0.8V typ.)

# MPM80 Series

## 7. External Dimensions

- TO220F-8L (Upright angle lead forming, MPM8x)

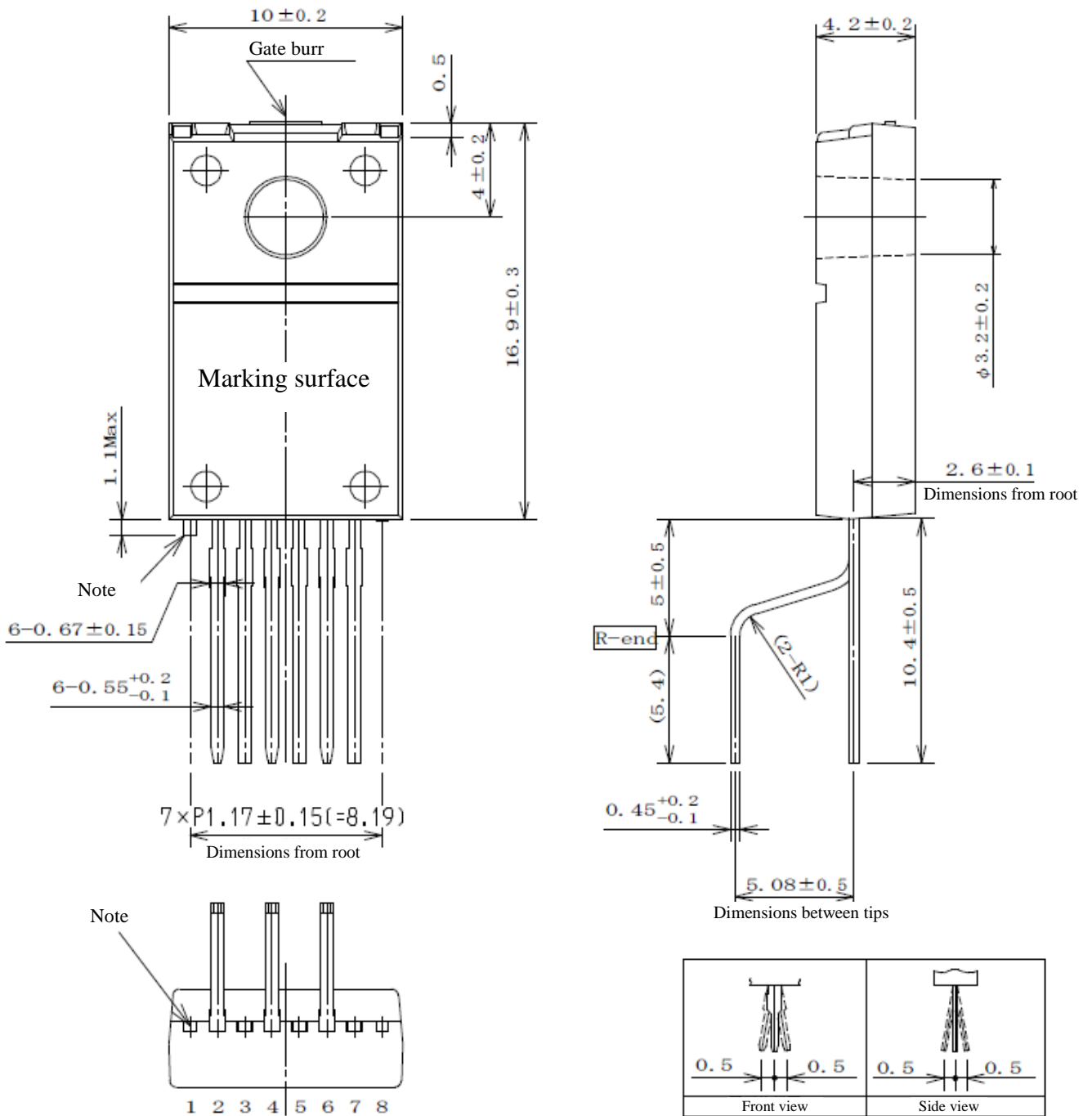

Notes:

- Unit: mm
- The arrows "Note" show the pin has been cut. Since the remained pin is live part, please pay attention to avoid the connection of the remained pin and the other live part pattern.
- "Gate burr" shows the position the gate burr with the height of 0.3mm (max.) is generated.
- Pb free (Device composition compliant with the RoHS directive.)
- Screw tightening torque: 6 to 8 kgf·cm

## MPM80 Series

- TO-220F-8L (Right angle lead forming, MPM8x-R)

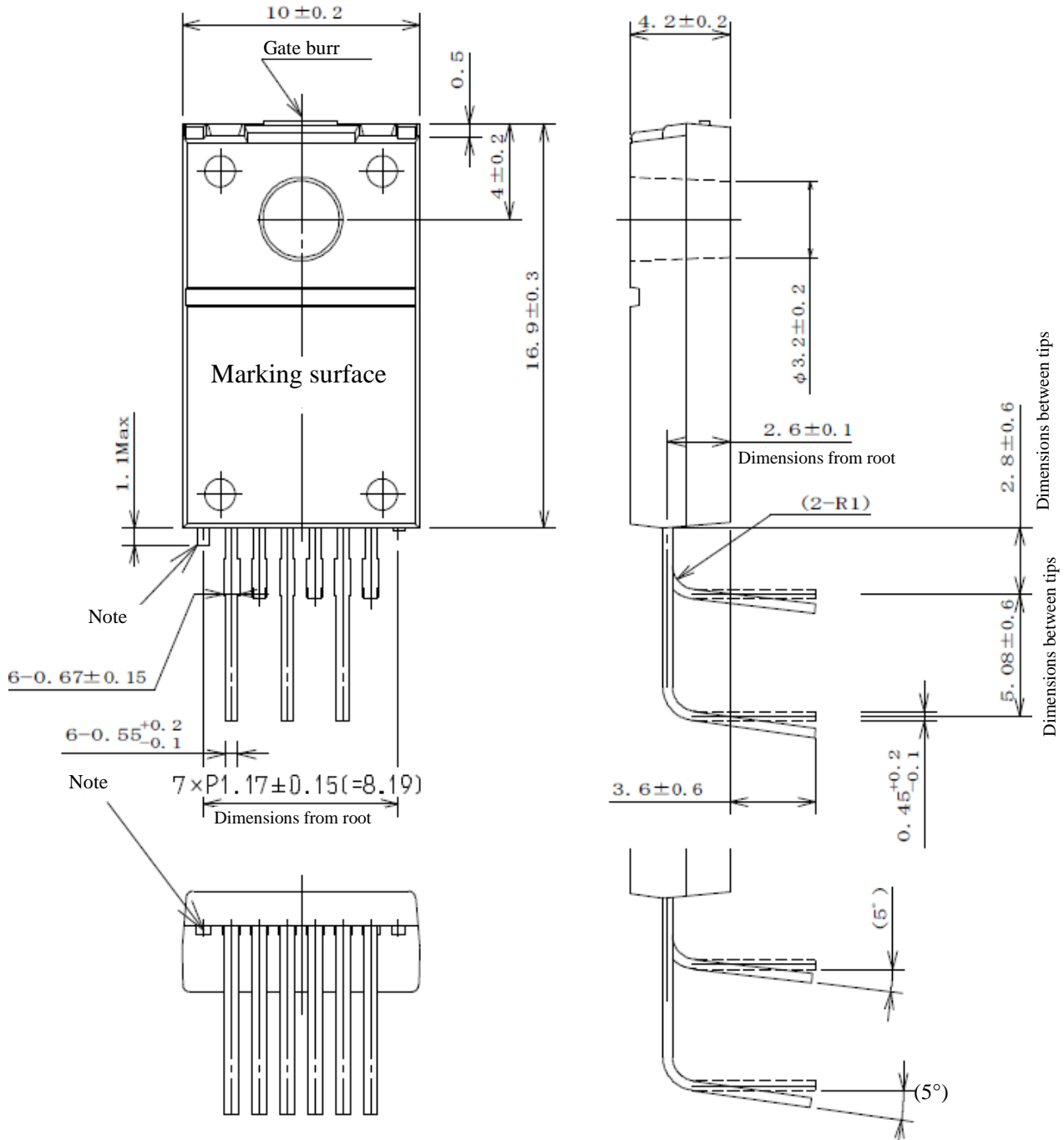

### Notes:

- 1) Unit: mm
- 2) The arrows "Note" show the pin has been cut. Since the remained pin is live part, please pay attention to avoid the connection of the remained pin and the other live part pattern.
- 3) "Gate burr" shows the position the gate burr with the height of 0.3mm (max.) is generated.
- 4) Pb free(Device composition compliant with the RoHS directive.)
- 5) Screw tightening torque: 6 to 8 kgf·cm

\* This figure shows the exaggeration of the lead condition.

It may differ from the actual bending shape.

### 8. Marking Diagram

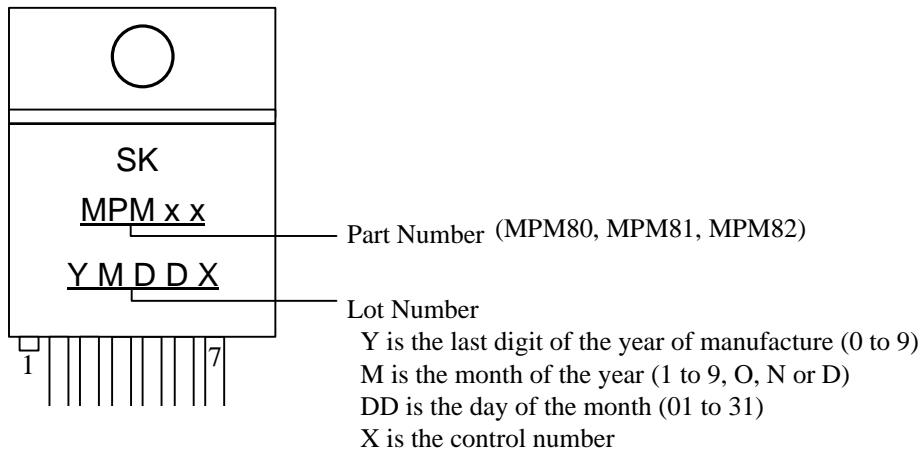

### 9. Operational Description

MPM80 series is the simple switching regulator module with incorporated inductor. This product can be used just by inserting a capacitor for input/output like conventional three pin regulator IC.

#### 9.1 Startup and Stop

The module starts operation when the applied voltage exceeds the UVLO release voltage (6.5 V typ.). The output voltage of VO pin,  $V_O$ , becomes the setting value when VIN pin voltage increases to the minimum difference of input/output (3 V min.) or more.

It stops operation similarly when the VIN pin voltage decreases to the UVLO voltage (7 V typ.).

Since the module does not have ON/OFF function by external signal,  $V_O$  turns ON/OFF according to the ON/OFF of power supply.

The module has soft start function.  $V_O$  rises if the VIN pin voltage increases to the UVLO release voltage or more. The soft start function is activated for 6.4 ms (typ.). The soft start time is fixed in the module and cannot be adjusted externally.

#### 9.2 Overcurrent Protection

The module has drooping type overcurrent protection.

The peak current is detected by pulse-by-pulse while the high-side MOSFET in the incorporated IC chip is on status. When the peak current exceeds the set value, the output voltage of VO pin,  $V_O$ , is decreased by forcibly shortening the on time of MOSFET. Furthermore, when  $V_O$  decreases, the switching frequency decreases in order to reduce power dissipation in the range of low  $V_O$ .

$V_O$  is automatically recovers when the factors of overcurrent are removed.

#### 9.3 Overvoltage Protection

The overvoltage protection of the module is the protection for the output voltage. This protection is not for the input overvoltage. If the applied voltage of VO pin or FB pin (in MPM80) becomes 1.1 times in set value for some reason, the switching operation stops in latch status.

The IC turns to normal operation when the factors of overvoltage are removed and the IC is restarted.

#### 9.4 Thermal Shutdown

Thermal shutdown circuit detects junction temperature of internal MIC. When the temperature exceeds the MIC shutdown start temperature (150 °C typ.), MOSFET switching operation is stopped. It automatically restarts when the junction temperature decreases to MIC shutdown start temperature by stopping switching operation.

The thermal shutdown of the module is the protection circuit for IC against heat generation such as transient short circuit. The operation comprising reliability of the situation where a heat generation continues such as a short circuit for long period is not guaranteed.

### 10. Design Notes

#### 10.1 Derating Curve

Figure10-1 shows the derating curve of MPM82. For MPM80 series, it is necessary to reduce the rate according to the actual ambient temperature,  $T_A$ .

The module must be used within the range of the curve in Figure10-1. The heatsink may be required in order to use the module within the absolute maximum ratings that the junction temperature,  $T_j$ , is 125 °C or lower.

The junction temperature,  $T_j$  is calculated from the Equation (2).

$$T_j = P_{\text{LOSS}} \times \theta_{j-H} \quad (2)$$

Where,

$P_{\text{LOSS}}$ : Internal loss (W)

$\theta_{j-H}$ : Thermal resistance between junction and heatsink (°C/W)

Internal loss,  $P_{\text{LOSS}}$ , is expressed by the Equation (3).

$$P_{\text{LOSS}} = (I_{\text{IN}} \times V_{\text{IN}}) - (I_{\text{O}} \times V_{\text{O}}), \quad (3)$$

where,

$I_{\text{IN}}$  is input current (A),

$V_{\text{IN}}$  is input voltage (V),

$I_{\text{O}}$  is output current (A) and

$V_{\text{O}}$  is output voltage (V).

## MPM80 Series

Thermal resistance between junction and heatsink  $\theta_{j-H}$  is expressed by the Equation (4).

$$\theta_{j-H} = \theta_{j-c} + \theta_H, \quad (4)$$

where,

$\theta_{j-c}$  is thermal resistance between junction and case 8 °C/W and

$\theta_H$  is thermal resistance of heatsink (°C/W).

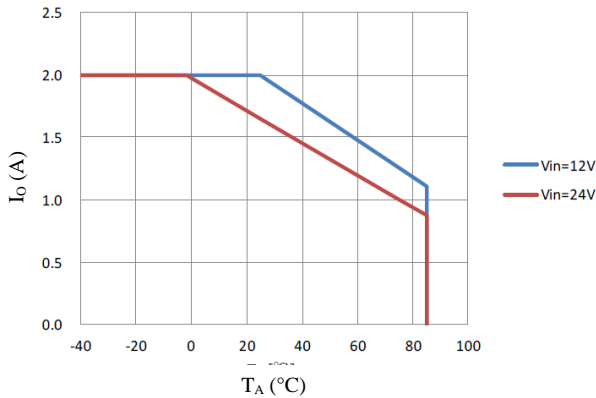

Figure10-1 MPM80 series derating curve

## 10.2 External Components

Each component should meet the conditions of use.

The symbol of using in following description is shown in Figure 6-1 and Figure 6-2.

### 10.2.1 Input Smoothing Capacitor C<sub>IN</sub>

The input capacitor, C<sub>IN</sub>, is the bypass capacitor of input circuit. C<sub>IN</sub> supplies short current pulses to the regulator, and compensates the input voltage drop. C<sub>IN</sub> should be connected close to the module. If the rectifying capacitor of secondary rectifier circuit such as flyback converter is input side of the module and is not close to the module, C<sub>IN</sub> must be connected close to the module.

Not only the lifetime reduction of capacitor, but also the abnormal oscillation may be caused if C<sub>IN</sub> is used under the following conditions:

Over the breakdown voltage of C<sub>IN</sub>.

Over the allowable ripple current of C<sub>IN</sub>.

Without derating for the breakdown voltage and allowable ripple current.

The sufficient margin to the ripple current is required for C<sub>IN</sub>. The ripple current, I<sub>CIN</sub>, is calculated by Equation (5).

It should be noted that C2 shown in Block Diagram of Section 4 is small capacitor for filter, and is included in the module. It is not for input smoothing capacitor.

$$I_{CIN} \approx 1.2 \times \frac{V_{OUT}}{E_{IN}} \times I_O, \quad (5)$$

where,

I<sub>CIN</sub> is effective value of the ripple current that flows across C<sub>IN</sub> (Arms),

V<sub>OUT</sub> is output voltage (V),

E<sub>IN</sub> is power source voltage for V<sub>IN</sub> pin (V) and

I<sub>O</sub> is output current (A).

### 10.2.2 Output Smoothing Capacitor C<sub>OUT</sub>

C<sub>OUT</sub> is the smoothing capacitor of output.

The sufficient margin to the breakdown voltage and ripple current is required for C<sub>OUT</sub> like the input smoothing capacitor.

The output current is equal to the ripple current  $\Delta I_L$  of inductor, L1, incorporated in the module, and charges and discharges for C<sub>OUT</sub>. The ripple current of C<sub>OUT</sub>, I<sub>COUT</sub>, is calculated from the Equation (6) to (8).

$$t_{ON} = \frac{V_{OUT}}{E_{IN}} \times \frac{1}{f} \quad (6)$$

$$\Delta I_L = \frac{(E_{IN} - V_{OUT})}{L} \times t_{ON} \quad (7)$$

$$I_{COUT} = \frac{\Delta I_L}{2\sqrt{3}} \quad (8)$$

where,

I<sub>COUT</sub> is effective value of ripple current that flows across C<sub>OUT</sub> (Arms),

t<sub>ON</sub> is effective value of on time of internal MOSFET (s),

V<sub>OUT</sub> is output voltage (V),

E<sub>IN</sub> is power source voltage for V<sub>IN</sub> pin V<sub>IN</sub> (V),

f is operating frequency of 630 kHz (typ.),

$\Delta I_L$  is the ripple current of internal inductor, and

L<sub>1</sub> is internal inductance value of 5.6  $\mu$ H (typ.).

It should be noted that C3 shown in Block Diagram of Section 4 is small capacitor for filter, and is included in the module.. It is not for output smoothing capacitor.

### 10.2.3 Output Voltage Setup Resistor (for MPM80)

The carbon film resistor or the metal oxide film resistor should be used for R1 and R2 shown in Figure 6-1. If the wirewound resistor is used in the application, the malfunction might be caused by the inductance of wirewound resistor.

## 10.3 PCB Layout

- 1)  $C_{IN}$  and  $C_{OUT}$  should be placed as close to the module as possible.
- 2)  $R2$  and  $R3$  should be placed as close to the module as possible. If the layout connected to FB pin is long, the malfunction may be caused due to interference such as switching noise. The pattern between  $R2$  and  $R3$ , and between  $R2$  and FB pin should be short as possible. (The pattern between output voltage line and  $R3$  should be long if the output line and FB pin

are distant.)

- 3)  $R1$  should be connected to S-GND from FB pin.
- 4) The switching current flows through P-GND from  $C_{OUT}$ , and the voltage drop is caused by the common impedance of the GND loop and the switching current. If the GND of output detection resistor,  $R1$ , is connected to this pattern, the load regulation may be deteriorated.

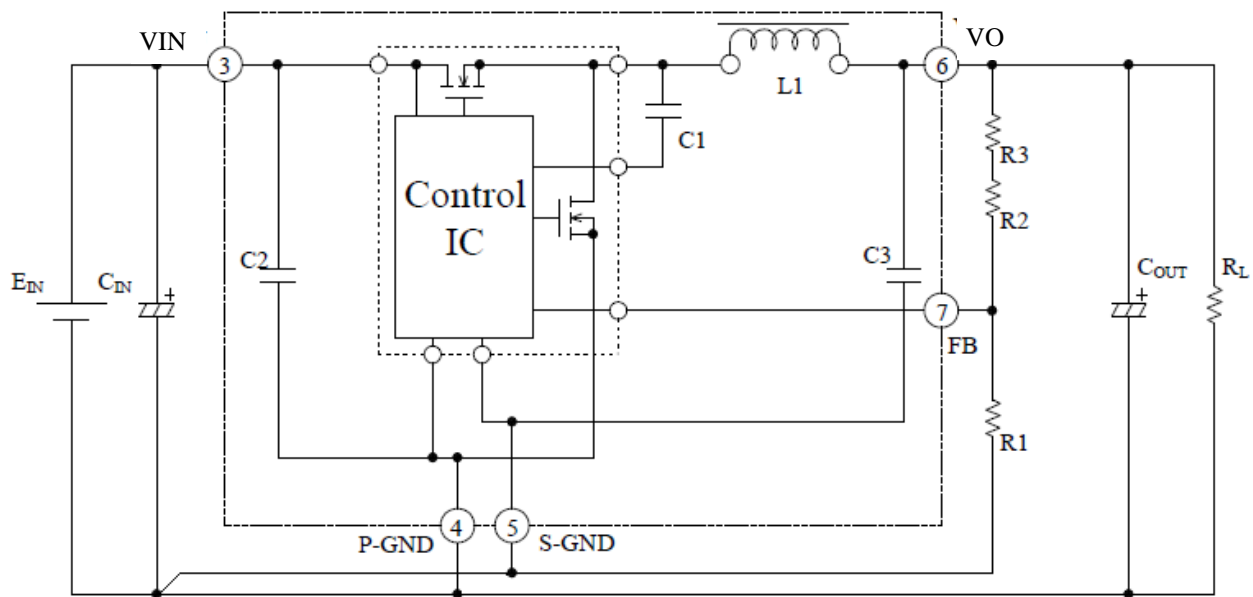

Figure 10-2 MPM80 Typical Application

11. Pattern Layout

Figure11-1 shows the PCB pattern layout as a reference, and Figure11-2 shows a circuit diagram.

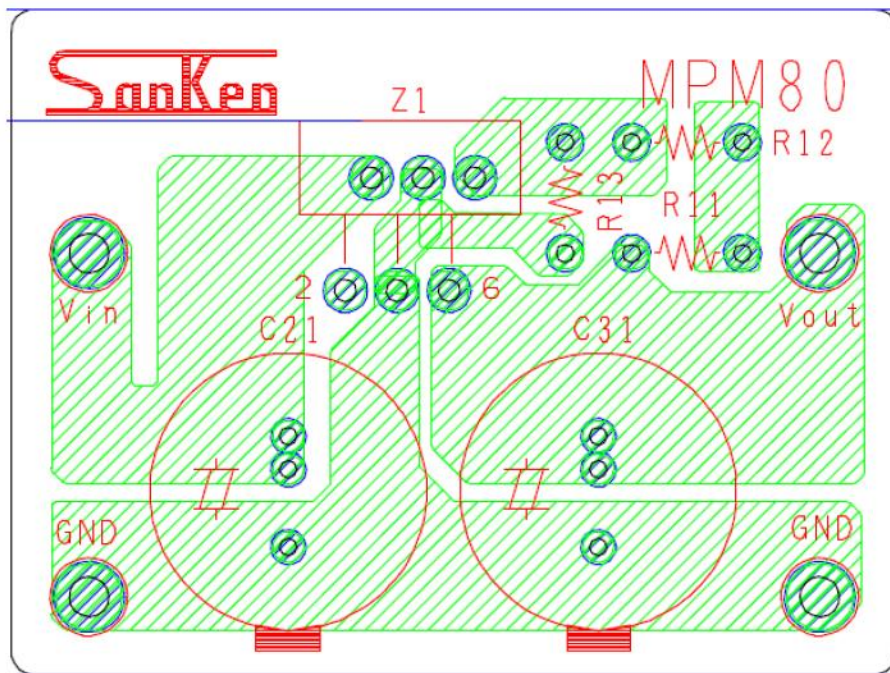

Figure11-1 Pattern layout

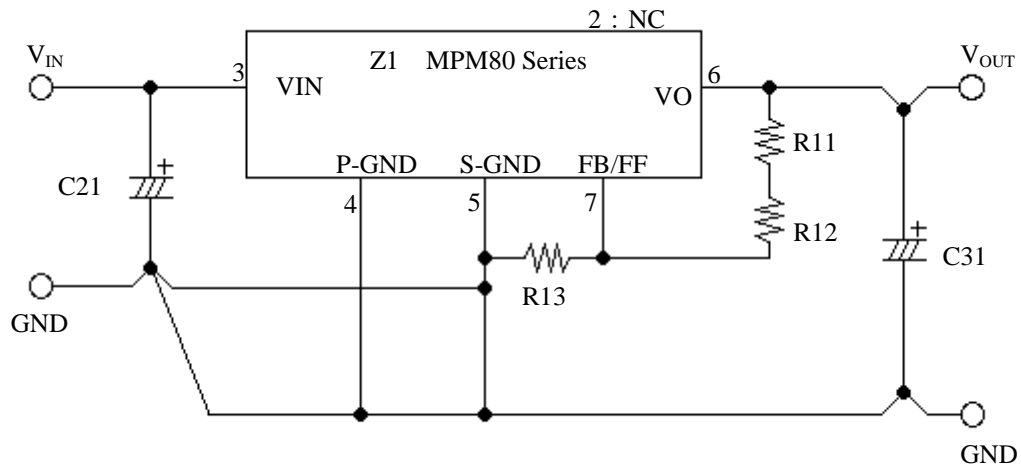

Figure11-2 Circuit diagram of pattern layout



12. Electrical Characteristics

12.1 MPM80

Test conditions:  $T_A = 25\text{ }^\circ\text{C}$ ,  $V_O = 5\text{ V}$

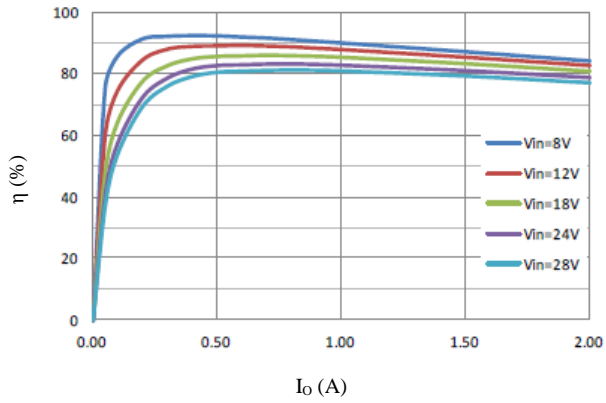

Figure 12-1 Efficiency characteristics

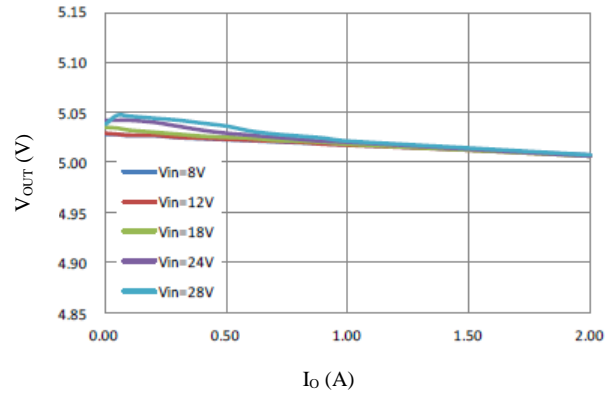

Figure 12-2 Load regulation

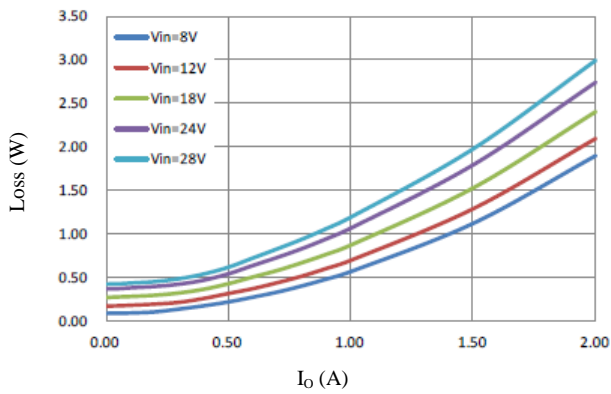

Figure 12-3 Internal loss

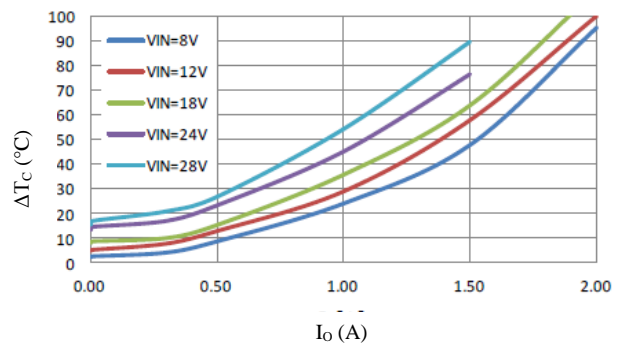

Figure 12-4 Temperature rise

# MPM80 Series

## 12.2 MPM81

Test conditions:  $T_A = 25\text{ }^\circ\text{C}$

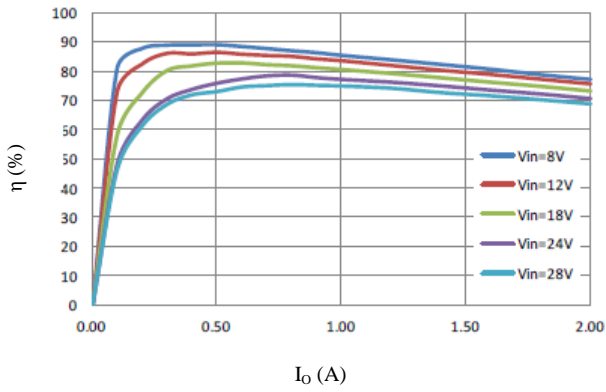

Figure 12-5 Efficiency characteristics

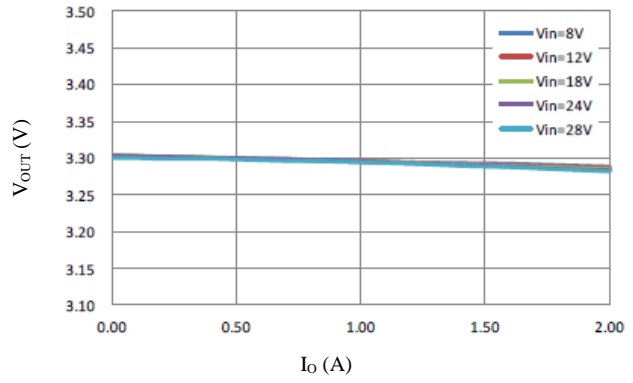

Figure 12-6 Load regulation

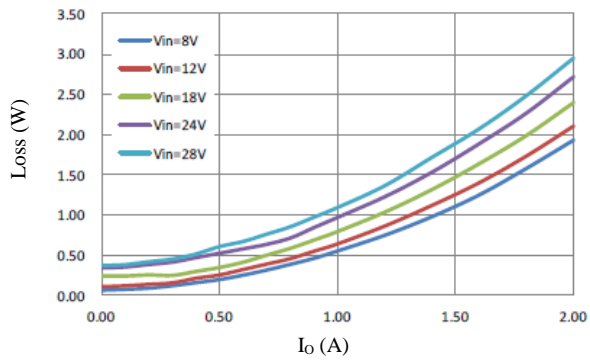

Figure 12-7 Internal loss

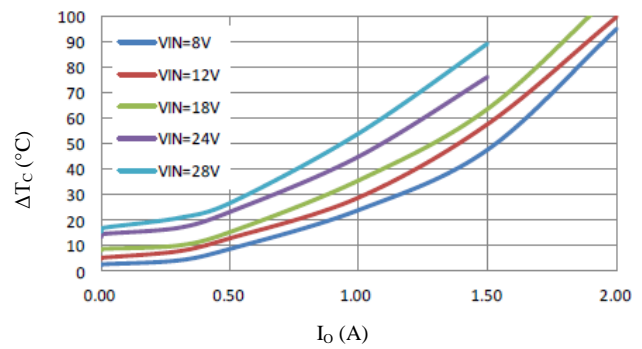

Figure 12-8 Temperature rise

# MPM80 Series

## 12.3 MPM82

Test conditions:  $T_A = 25\text{ }^\circ\text{C}$

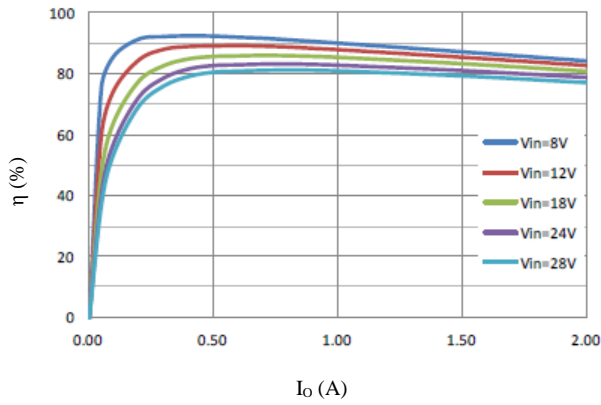

Figure 12-9 Efficiency characteristics

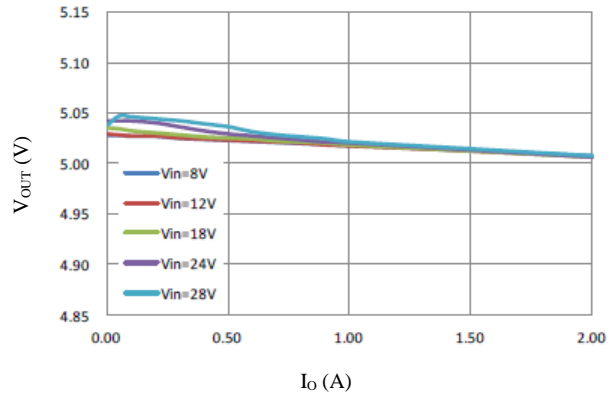

Figure 12-10 Load regulation

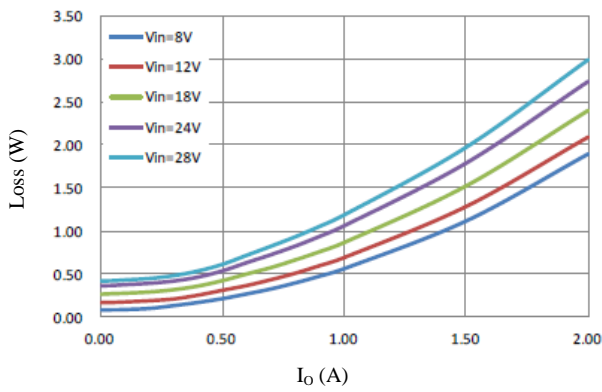

Figure 12-11 Internal loss

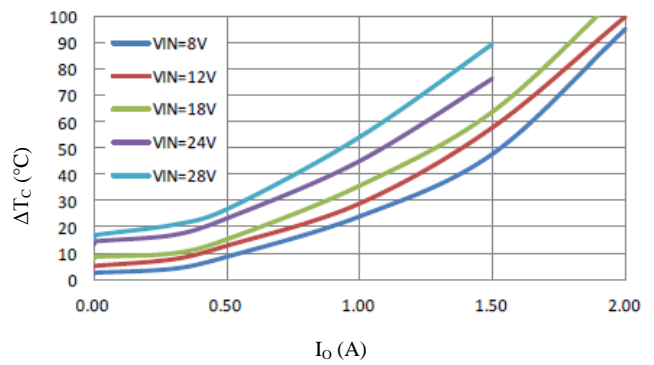

Figure 12-12 Temperature rise

### IMPORTANT NOTES

- All data, illustrations, graphs, tables and any other information included in this document as to Sanken's products listed herein (the "Sanken Products") are current as of the date this document is issued. All contents in this document are subject to any change without notice due to improvement of the Sanken Products, etc. Please make sure to confirm with a Sanken sales representative that the contents set forth in this document reflect the latest revisions before use.
- The Sanken Products are intended for use as components of general purpose electronic equipment or apparatus (such as home appliances, office equipment, telecommunication equipment, measuring equipment, etc.). Prior to use of the Sanken Products, please put your signature, or affix your name and seal, on the specification documents of the Sanken Products and return them to Sanken. When considering use of the Sanken Products for any applications that require higher reliability (such as transportation equipment and its control systems, traffic signal control systems or equipment, disaster/crime alarm systems, various safety devices, etc.), you must contact a Sanken sales representative to discuss the suitability of such use and put your signature, or affix your name and seal, on the specification documents of the Sanken Products and return them to Sanken, prior to the use of the Sanken Products. The Sanken Products are not intended for use in any applications that require extremely high reliability such as: aerospace equipment; nuclear power control systems; and medical equipment or systems, whose failure or malfunction may result in death or serious injury to people, i.e., medical devices in Class III or a higher class as defined by relevant laws of Japan (collectively, the "Specific Applications"). Sanken assumes no liability or responsibility whatsoever for any and all damages and losses that may be suffered by you, users or any third party, resulting from the use of the Sanken Products in the Specific Applications or in manner not in compliance with the instructions set forth herein.
- In the event of using the Sanken Products by either (i) combining other products or materials therewith or (ii) physically, chemically or otherwise processing or treating the same, you must duly consider all possible risks that may result from all such uses in advance and proceed therewith at your own responsibility.
- Although Sanken is making efforts to enhance the quality and reliability of its products, it is impossible to completely avoid the occurrence of any failure or defect in semiconductor products at a certain rate. You must take, at your own responsibility, preventative measures including using a sufficient safety design and confirming safety of any equipment or systems in/for which the Sanken Products are used, upon due consideration of a failure occurrence rate or derating, etc., in order not to cause any human injury or death, fire accident or social harm which may result from any failure or malfunction of the Sanken Products. Please refer to the relevant specification documents and Sanken's official website in relation to derating.
- No anti-radioactive ray design has been adopted for the Sanken Products.
- No contents in this document can be transcribed or copied without Sanken's prior written consent.
- The circuit constant, operation examples, circuit examples, pattern layout examples, design examples, recommended examples, all information and evaluation results based thereon, etc., described in this document are presented for the sole purpose of reference of use of the Sanken Products and Sanken assumes no responsibility whatsoever for any and all damages and losses that may be suffered by you, users or any third party, or any possible infringement of any and all property rights including intellectual property rights and any other rights of you, users or any third party, resulting from the foregoing.
- All technical information described in this document (the "Technical Information") is presented for the sole purpose of reference of use of the Sanken Products and no license, express, implied or otherwise, is granted hereby under any intellectual property rights or any other rights of Sanken.
- Unless otherwise agreed in writing between Sanken and you, Sanken makes no warranty of any kind, whether express or implied, including, without limitation, any warranty (i) as to the quality or performance of the Sanken Products (such as implied warranty of merchantability, or implied warranty of fitness for a particular purpose or special environment), (ii) that any Sanken Product is delivered free of claims of third parties by way of infringement or the like, (iii) that may arise from course of performance, course of dealing or usage of trade, and (iv) as to any information contained in this document (including its accuracy, usefulness, or reliability).
- In the event of using the Sanken Products, you must use the same after carefully examining all applicable environmental laws and regulations that regulate the inclusion or use of any particular controlled substances, including, but not limited to, the EU RoHS Directive, so as to be in strict compliance with such applicable laws and regulations.
- You must not use the Sanken Products or the Technical Information for the purpose of any military applications or use, including but not limited to the development of weapons of mass destruction. In the event of exporting the Sanken Products or the Technical Information, or providing them for non-residents, you must comply with all applicable export control laws and regulations in each country including the U.S. Export Administration Regulations (EAR) and the Foreign Exchange and Foreign Trade Act of Japan, and follow the procedures required by such applicable laws and regulations.
- Sanken assumes no responsibility for any troubles, which may occur during the transportation of the Sanken Products including the falling thereof, out of Sanken's distribution network.
- Although Sanken has prepared this document with its due care to pursue the accuracy thereof, Sanken does not warrant that it is error free and Sanken assumes no liability whatsoever for any and all damages and losses which may be suffered by you resulting from any possible errors or omissions in connection with the contents included herein.
- Please refer to the relevant specification documents in relation to particular precautions when using the Sanken Products, and refer to our official website in relation to general instructions and directions for using the Sanken Products.

DSGN-CEZ-16001